

SGT. WEBSTER, JOHN P. JR.

82ND COMBAT SECURITY
WING (TAC)



WING TRAINING CENTER

STUDENT HANDBOOK



UNIT HISTORY

1. DEVELOPING THE CONCEPT

During the initial involvement of the USAF Security Police units in the Vietnam insurgency, internal security of remote and vulnerable air bases was still carried out under the long existing concept of providing internal protection for resources against the covert threat of sabotage. Internal security for air bases located in forward areas was geared to detect, capture or destroy a small covert group that would, by clandestine means, attempt to destroy aircraft or other priority resources.

After the attacks by well organized and well trained guerilla raiding parties on the air bases at DaNang and Bien Hoa, the USAF Security Program was forced to re-direct its attention to providing a well-trained, well armed and well motivated combat security force, capable of engaging and repelling commando type raids by enemy forces, before those forces could cause destruction or damage to sensitive base areas.

Under the direction of Lt Gen Glenn Martin, USAF Inspector General, a security survey was conducted in Vietnam in November, 1965 and the results of that survey were presented to the Chief of Staff, USAF, with the recommendation that a unit of highly trained Security Police personnel be formed to test a newly developed concept of active ground defense at a designated site in the Republic of Vietnam.

2. RECRUITING AND TRAINING

With Chief of Staff concurrence recruiting for the special program began in the CONUS in early 1966. After careful consideration, the US Army Ranger School at Fort Benning, Georgia was selected as the initial training program for the original cadre of the special unit. Personnel selected through the

personal interviews were sent to Fort Benning and began the first class of Ranger School for Air Force personnel on 4 May 1966.

3. THE SQUADRON IS FORMED

Designated by the project code name of "OPERATION SAFESIDE", the 1041st USAF Security Police Squadron (Test) was formed at Schofield Barracks, Hawaii in August, 1966 under the command of Lt Col William H. Wise, Sr. Volunteers for the unit were selected from installations throughout CONUS and PACAF, and the prospective trainees arrived at Schofield Barracks on 1 September 1966.

4. INDIVIDUAL TRAINING PHASE

On 1 September the arduous, rigorous, and somewhat hazardous individual training program began. Based on the Ranger concept of operations, with emphasis on weapons, each trainee was evaluated on his ability to react to combat decisions while under a great deal of emotional, physical and mental stress. With emphasis on small unit leadership and tactics, these first trainees participated in a training program unprecedented in Air Force history. On 4 November 1966, at the conclusion of a 30 mile forced march, the individuals passed from their personal test into unit training.

5. UNIT TRAINING

A 6 week unit training period was commenced on 10 November 1967 during which the unit was welded together as a functioning combat organization composed of cadre and former students. Specialized training was also conducted during this training and several important precedents for an Air Force unit established. For the first time, the Air Force had its own organized Mortar Section, Sniper Team, Armored Personnel Carrier section, Observation and Surveillance Element, Close Combat Flight, TSSE Section and Scout Dog unit. Upon

completion of specialized training, the unit conducted extensive field exercises under conditions that it was known would be faced by the unit in Vietnam. The successful conclusions of these field exercises clearly indicated that the unit was ready for combat.

6. THE SQUADRON DEPLOYS

In November 1966, Phu Cat Air Base, an essentially bare base operation in the Central Highlands of Vietnam whose runway was still under construction, was selected as the test site for the 1041st USAF SPS (T). In addition to the defense of the base, the 1041st was charged with the responsibility of testing the operation and deployment of the newly developed Tactical Security Support Equipment (TSSE), a sophisticated system of field intrusion detection devices.

On 15 December 1966, 33 personnel of the 1041st departed Hickam AFB, Hawaii enroute to Phu Cat to establish an operating base for the unit. The bulk of the squadron departed Hickam on 10 Jan 67 and arrived at the port city of Qui Nhon on 13 Jan 67 and preceded by motor convoy to Phu Cat.

7. TACTICAL AREA OF RESPONSIBILITY (TAOR)

During the period 13 Jan to 4 July 1967, the 1041st had a Tactical Area of Responsibility that covered 9.3 square miles of jungle, rice paddies and heavily vegetated terrain that lended itself well to infiltration by guerilla units. Of the total 10,000 acres of land that composed Phu Cat Air Base, 6,000 acres were the responsibility of the 1041st to secure and defend against enemy infiltration.

8. OPERATIONAL TEST PHASE

The concept of active defense at Phu Cat included such tactics as daylight recon patrols, manning of forward observation posts during the day, and listening posts at night, operation of tactical motor patrols with gun jeeps, sweep and clear operations, relocation of areas of population, and the use of the primary

tactic in counter-insurgency operations: The Ambush Patrol.

Ambushes conducted at Phu Cat provided the most tangible enemy contacts. Ambushes of fire team size, and less, were conducted at different locations within the established curfew zones of the 1041st on a nightly basis, their locations constantly changing. These locations were based on daily intelligence data and known vulnerable avenues of approach. The 1041st experienced continuous probing by Viet Cong elements attempting to enter the base for reconnaissance purposes. Enemy efforts to infiltrate the base were consistently frustrated by the 1041st, as reflected by several captured enemy documents attesting to the fact that the local guerilla forces were unable to operate freely around Phu Cat due to the presence of "an elite Blue Beret security force" operating in the area.

9. RESULTS

The true measure of any program lies in the results achieved. Aside from the fact that the presence of the 1041st prevented the enemy from massing an attack on the air base, even after the arrival of a tactical fighter wing to the base, their were more tangible results to be observed. During its operations at Phu Cat, the 1041st participated in search and clear operations that netted seventy one (71) suspect VC, of which six (6) were later proved to be confirmed Viet Cong, and twenty two (22) others further detained as strong suspects. Two (2) Vietnamese Nationals were detained as deserters from the Army of Vietnam.

On 3 May 1967, a two man Sniper Ambush team engaged a Viet Cong patrol, killing one of its members. The individual killed had in his possession a courier pouch containing many intelligence documents of great importance to friendly forces in the area.

On 21 May 1967 a linear ambush was conducted by the TSSE Section resulting in the death of an enemy member later identified as the VC District Commissioner of An Nhon Province and Chief of the VC Security Assault forces.

These two dramatic kills lend further credence to the value of the active defense tactics developed and employed by the 1041st in Vietnam.

10. PREPARATION FOR DEPARTURE

The 1041st prepared for its departure from Vietnam by training selected volunteers of the 37th Security Police Squadron at Phu Cat Air Base in tactics that the 1041st had employed and introduced to the Phu Cat area, in order to provide a program of active defense for the area after the departure of the 1041st.

Upon completion of the test phase and training for the local security police personnel, the 1041st departed Phu Cat and arrived at Fairchild AFB, Washington on 4 and 6 July 1967.

INTRODUCTION

You, while here at the 4470th Combat Security Wing Training Center, will be faced with a trying test of mental and physical endurance. The training is designed to further select from volunteers, those most capable of fulfilling this concept of global Air Force missions and commitments.

You as an individual must search within yourself and often tax yourself in order to meet the minimum requirements of the challenge placed before you in this school. Your energies will be strained to the utmost in order that you will reach the goal to which you are aspiring. Many of you will face physical and sometimes emotional stresses that you have never been required to face before. For those of you who complete this training, there will be satisfaction in knowing that you have faced the challenges of a rigorous training program, and are mentally and physically prepared to face the rigors and challenges of combat situations.

With the best wishes of the cadre and school staff,

"DRIVE ON"!

THE STUDENT HANDBOOK

This student handbook has been developed by members of the cadre training staff to assist the student in notetaking during academic portions of the training and to provide a ready reference for each student. The handouts inserted in each chapter of this handbook will be referred to in class by the instructors, therefore each student will insure that this handbook is in his possession when attending classes. To get the maximum benefit from this handbook, the student should never attempt to use the material as a teaching by himself. This handbook is only a guide for the student, and an administrative supplement to the information and techniques learned in each academic class. Protect this handbook. It will be a useful tool in your learning process.

TRAINING MISSION

The mission of this Wing Training Center is to train selected Air Force personnel to meet the arduous mental and physical demands of an active ground defense concept to provide protection through security in depth for Air Force missions directed against overt enemy threats in an insurgent environment, within USAF global operations.

1. During the course of your training the uniform of the day will be specified by the cadre staff. Uniform combinations will be identified by the titles given below, and each student will insure that he understands the equipment requirements of each uniform combination.

a. Student Field Uniform: This uniform will be worn to all academics, field problems, read marches, and as directed. The following items will be worn:

(1) Fatigues, blouse trousers, fatigue cap, and field gear as follows:

- (a) Harness
- (b) Web belt
- (c) Canteen, with cup and cover
- (d) First Aid pack, with pouch
- (e) Snake Bite Kit
- (f) Bayonet
- (g) Ammo Pouches
- (h) Pouches
- (i) Compass (secured with belt ~~l~~ around neck)
- (j) Snap link and sling rope
- (k) Notebook and pen

(1) Gloves

b. Student Field Uniform with Weapon: Same as student field uniform, with the following items added:

- (1) Weapon
- (2) Second canteen, with cup and cover
- (3) Helmet and helmet liner

c. Full Field Uniform: This uniform will be worn when scheduled for any extended stay in the field. Same as student uniform with weapon, except except for the addition of the following items:

- (1) Pack to contain:
 - (a) Extra fatigues
 - (b) Two pair socks
 - (c) Two sets underwear
 - (d) Toilet articles
 - (e) Mess Kit, complete
 - (f) Shelter Half, complete
 - (g) Flashlight

d. PT Uniform: This uniform will be worn to all morning PT formations and as directed:

(1) Fatigue uniform

(a) Fatigue shirt worn outside trousers.

(b) Trousers bloused

(c) Hats will not be worn.

STUDENT CONDUCT

SCOPE: This directive will apply to all personnel in student status in the Wing Training Center.

POLICY: The following procedures will apply:

Command: All students will be responsible to the student staff for all matters regarding their location during training hours. The student staff will coordinate all matters of flight business with the Flight TAC NCO and/or officers. All changes in the training schedule or placement of personnel will come only from the TAC Officer or TAC NCO.

Conduct: Each student will insure that he will conduct himself in such a manner that he will meet all scheduled activities. During free time it is understood that the conduct of the individuals personal affairs will be uppermost in his mind, and sufficient time will be scheduled throughout the training cycle to see that this is done. If the student is allowed off-station at any time, his conduct will not bring discredit to the unit. Disciplinary actions or injuries received as a result of off-duty incidents reduce student effectiveness, results in lost training time that the student cannot afford, and may well result in the students dismissal.

Appearance: The student uniforms are outlined in the preceding pages of this handbook. The specified uniform requirement for training will be met at all times. With the exception of field training conditions, at no time will a student leave the squadron area, attend meals, or report to an Officer without a clean uniform. During the off-duty hours, the student will wear appropriate civilian clothing or military uniform.

Personal Hygiene: Each student will shave daily, even during field exercises, where personal hygiene becomes critical to avoid skin disorders and diseases. Showers will be taken daily when in garrison, and by whatever means possible when in the field. Each student will shower after morning PT. Socks will be changed daily, boots retated during the entire training. Each student will be clean shaven, and a traditional "GI" haircut will be worn by all students.

Personal and Organizational Equipment: All ~~items~~ of equipment will be clean, serviceable and accounted for at all times. Upon returning from the ranges, field, or any activity where your weapon and equipment will be dirty, time will be allotted and your equipment will be cleaned, particularly your rifle. Personal clothing will be washed daily or as often as possible. Starched and pressed fatigues are not a requirement of this school, however your fatigues are expected to be clean and reasonable serviceable, your boots clean and black. Items of equipment that become unserviceable due to excessive wear or damage, or loss, will be reported through the student staff to the TAC NCO. Students will be held personally responsible for their equipment at all times.

Student/Cadre Relationship: The student will at all times stay within the area designated for students within the billeting area. At no time will the student seek off-duty or out of class relationships with members of the cadre. All contacts with the cadre will be made through the TAC NCO. Enlisted cadre members will be addressed as "Sergeant", Officers as "Sir". All requirements of military courtesy will prevail when in student status. At any time a student meets a cadre member, a greeting will be exchanged, initiated by the student.

CHAIN OF COMMAND

(to be filled in by student as applies)

SCHOOL COMMANDANT _____

TRAINING OFFICER _____

TRAINING NCO _____

TAC OFFICER OR NCO _____

STUDENT COMMANDER _____

STUDENT FIRST SERGEANT _____

STUDENT OPERATIONS SERGEANT _____

FLIGHT SERGEANT _____

SQUAD LEADER _____

STUDENT

THE IMPORTANCE OF UNDERSTANDING CIVIL AFFAIRS

Since the early days of the American Revolution, a clear tenet of counter-insurgency operations has emerged. The British Colonial Army learned too late that a counter revolution cannot be successful as long as the revolutionaries have the support or passive approval of the local people. During the revolution of 1776, an American Revolutionary Leader coined the term "winning the hearts and minds of the people".

During portions of your academic hours, you will be exposed to information on "Civil Affairs" and "Civic Action". The integration of this material into your training at this school may at first not be clear. However, a careful look at the socio-political conditions facing the Free World Forces operating in the Republic of Vietnam should clarify the need for understanding in this vital area of counter-insurgency warfare.

Southeast Asia has been the stage for three of the most complex and extensive attempts at Communist revolution in contemporary history. Valuable lessons have been learned by western and indigenous armies in dealing with the insurgencies in Malaya, the Phillipines, and Vietnam. Clearly, these lessons point out that victory in insurgent warfare cannot be achieved by military success alone. The now familiar phrase "winning the hearts and minds of the people" is more important in counter-guerrilla warfare today than when it was first stated almost 200 years ago.

Dealing with a civilian populace that is subject to terrorist tactics, skillful propaganda, regional and ethnic pressures to support local guerillas takes patience, knowledge and understanding. It also requires motivation and the desire to create the most amicable atmosphere possible for military operations.

Civil Affairs has always been important, but this has not always been recognized. The cause of many unsuccessful military operations can be traced to the disregarding of Civil Affairs by military and political leaders. Results in winning over the people to the side of the legally established

government are often intangible, seldom dramatic, and always a long, slow process. It is however, a requirement for bringing an insurgent situation to a successful conclusion, for either side. Neglect of Civil Affairs and Civic Action Programs invites economic and military instability, subversion, material for enemy propaganda, continuing guerrilla action, and loss of support by the population on whom the stability of the government depends.

The basic purpose of a Civil Affairs program is to provide the necessary trained military personnel and command organization for the administration of a military-civil relationship in an area in which our military forces are present, in times of peace or war. It is for this result that the Civil Affairs portion has been included in your training program.

F I R S T A I D

1. DEFINITION

First Aid is the immediate and temporary care given the victim of an accident, sudden illness or wound received in combat until the services of a physician or medical officer can be obtained.

First Aid commences with the steadying effect upon the victim when he realizes that competent and concerned hands will help him. The victim suddenly has new problems and needs. Often he cannot think well temporarily. Events may seem unreal and remote. His mind may be dull. The emotional reaction associated with a serious wound subsides only gradually. Therefore, First Aid is more than a dressing or a splint. It relates to the victims mind and spirit as well as to his physical wounds and injuries. The requirement for good first aid training in a combat security unit is obvious. Persons with a good background in first aid training knew how to deal with the whole situation the person, and the injury. Errors so commonly made through well meant but misguided efforts are avoided. The individual soldier with first aid training confines his procedures to what is necessary, recalling that handling of the injured parts should be kept to a minimum.



FIGURE.

2. FIRST AID TRAINING

During the initial phase of your training you will receive several hours of field instruction in techniques of first aid in combat situations. This training will not be all-encompassing or designed to make you an expert in First Aid. The goal of this training is to provide you with the basic knowledge required to give first aid to a wounded comrade in the field. You will be instructed in the latest techniques in artificial respiration, how to stop bleeding, and protection for massive wounds against infection. Modern warfare has provided for a remarkably swift and efficient combat air evacuation system that usually finds the victim of a combat wound at a forward hospital shortly after the wound has been received. With this in mind the first aid portion of your training has been developed to provide you with the rudimentary knowledge required to protect the wounded until air evacuation has arrived.

3. GIVING FIRST AID

Act quickly for wounds where each second of delay may be important, i.e., severe bleeding, stoppage of breathing where artificial may be necessary, and shock. The proper first aid will be taught to you in detail during your field training in this subject.

Keep the Victim Lying Down: Protect him from unnecessary movement and disturbance. Do not heat the wounded man, but keep his body temperature from falling. Blankets beneath the victim are usually more effective than over him, but there is a hazard in placing them before you know the full extent of injuries.

Check for Injuries: Your clues are the story of what happened, the victims reaction to his wounds, and your findings upon examination. The direction and extent of examination should be guided by the type

of wounds and the needs of the situation. Have a reason for what YOU DO. If urgent first aid has been given and the patient is properly protected pending the arrival of scheduled or requested air evacuation, an examination may not be necessary. If you must move the victim even a short distance for his protection before the medevac personnel arrive, you should first learn, if possible, what body parts are injured so that you can support them adequately during the transfer.

Suppose, however, that you must carry through with first aid and perhaps transport the victim. Here you must check carefully for injuries. Sometimes the task can be simple, because it involves a clearly exposed wound. In other cases you may recognize that allied wounds may be accompanying the major wound and require special consideration. With this type of wound you should assure yourself, through consideration of the above mentioned clues, about every body part. The head, neck, trunk, back, each extremity in turn. Remember always to consider head injuries and back injuries. With each part, think of surface injuries, of fractures, and of internal organ injury. In addition, note the patient's general condition, and state of consciousness.

Surface wounds and massive wounds are readily evident. Fracture and internal organ injuries present greater difficulties. Visual evidence may be lacking with the former and almost always with the latter. Therefore, your objective in checking for them is simple: Find what body parts are, or may be, injured. Your first aid should be aimed to keep these parts immobile. Checkup for injuries is far more accurate when the body parts are exposed. Utmost caution will be used when clothing is removed. When in doubt about a body part, keep it from twisting, bending and shaking, and do not jack-knife the patient. Do not pick him up by head and heels.

Plan What To Do: A radio request for air evacuation should be one of the first steps in treating the wounded individual. Medical evacuation helicopters can be enroute while you are further preparing the patient for movement. If helpers are needed, closely supervise them to preclude the possibility that your uncoordinated efforts will result in further injury or death to the wounded individual. Be prepared to give the medevac personnel a brief and clear rundown of the first aid you have already given the patient.

Carrying Out the Indicated First Aid: You will be taught how to treat each kind of wound or injury during your first aid training. Knowing what to do presents few difficulties, once the location and nature of the wounds are learned. Do not attempt to save time and effort by using second best methods of first aid. First, stop profuse bleeding. (Figures __ through __). Determine whether artificial respiration may be necessary. After that, you make take time for a more careful examination of the wounded person. Do not short out your knowlde and interest in first aid operations and paractices. Your life, and the lives of your comrades, may well depend on your ability to assist them with first aid, when this urgent help is needed.

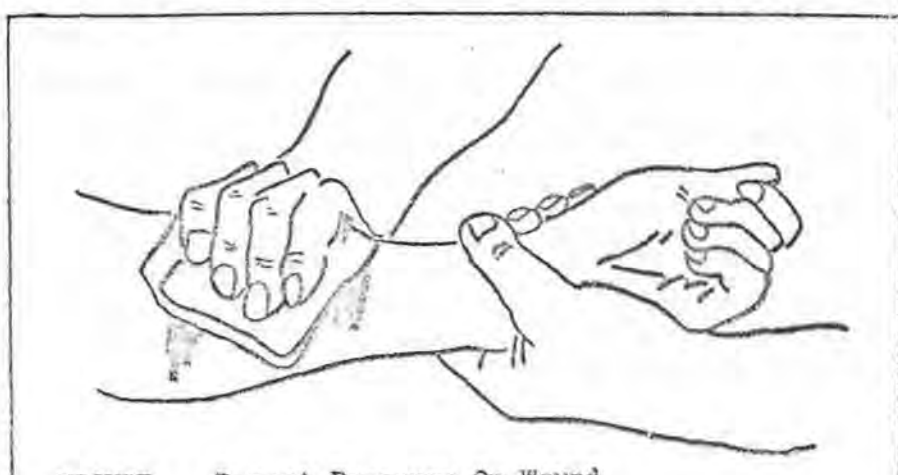

FIGURE Direct Pressure On Wound



FIGURE Direct Pressure on
The Wound (Brachial
Artery)

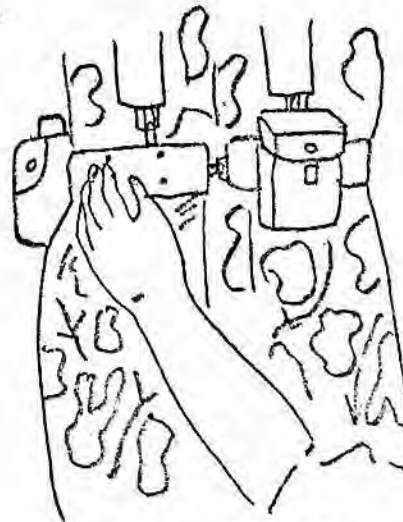

FIGURE Hand Pressure on
Femoral Artery

THE M-16 RIFLE

1. TECHNICAL DATA

The M-16 is an air cooled, gas operated, magazine fed, shoulder or hip fired, semi or fully automatic rifle.

Maximum Effective Range	500 yards
Maximum Range	2,833 yards
Maximum Rate of Fire	
Semi	45/65 rounds per min
Auto	150/200 rounds per min

2. FUNCTIONING

Each time the weapon is fired, many parts inside the rifle function in a given order. This is known as the "cycle of operation". A knowledge of what happens inside the rifle will help you understand the cause of, and remedy for, various stoppages and malfunctions.

The cycle of operation is divided into eight (8) steps: (1) firing, (2) unlocking, (3) cocking, (4) extracting, (5) ejecting, (6) feeding, (7) chambering, and (8) locking. Although described separately here, the functioning of the steps occur almost simultaneously. With the selector set for semi-automatic fire, a full magazine, and a round in the chamber, the following cycle of operation takes place each time the trigger is pulled, as depicted in the following pages of diagrams, beginning with Figure One (1).

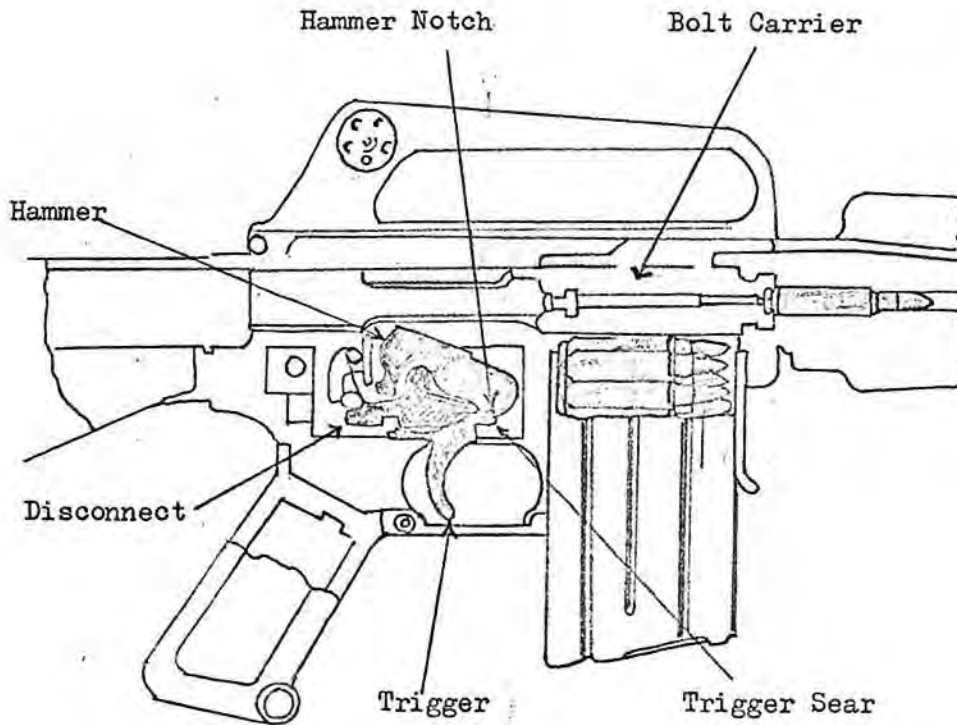

FIGURE 1. RIFLE READY TO FIRE

1. FIRING: The trigger rotates on the trigger pin causing the trigger gear to release the hammer. The hammer is forced forward by the hammer spring causing the hammer to strike the firing pin, which detonates the primer, firing the cartridge.

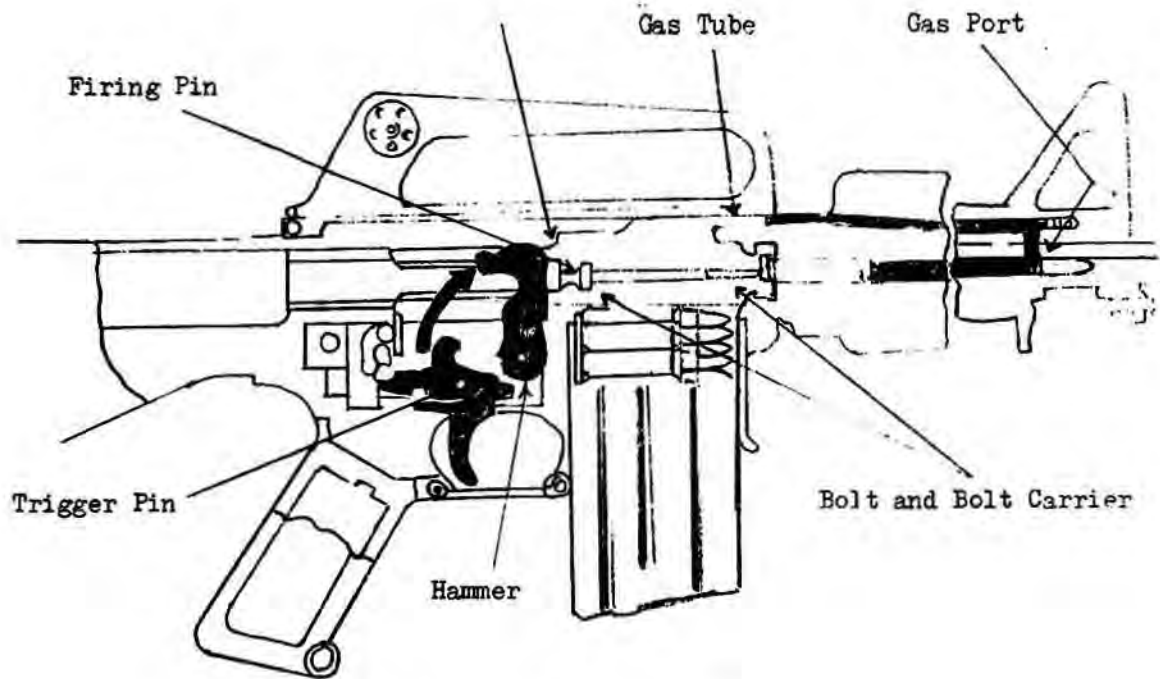

FIGURE 2. RIFLE BEING FIRED

Unlocking: Gas pressure from the burning powder drives the bullet down the barrel. As the bullet passes the gas port, gas is routed through the gas tube, through the bolt carrier key and into the cylinder formed by the bolt and bolt carrier. The gas pressure in the cylinder drives the bolt carrier to the rear, causing the bolt cam pin to rotate the bolt and disengage the bolt lugs of the barrel extension.

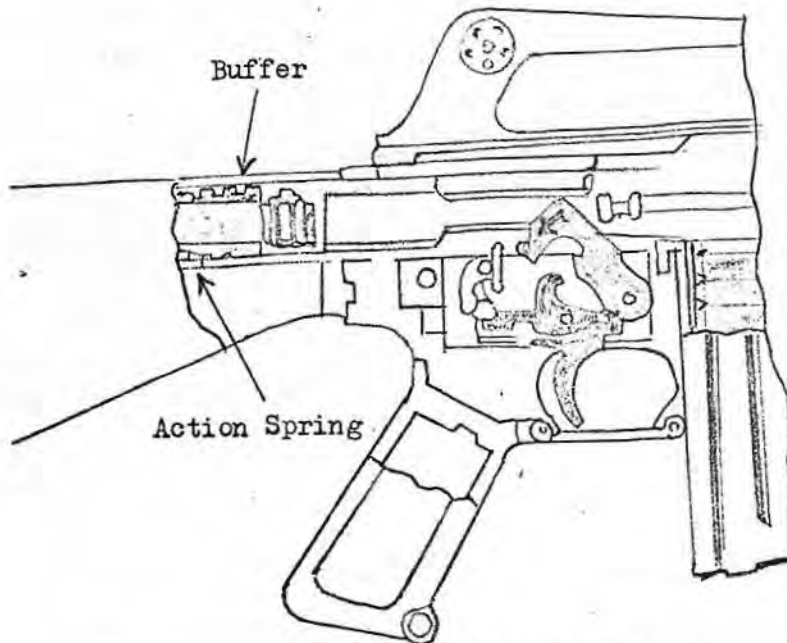

FIGURE 3. COCKING DURING REARWARD MOVEMENT OF BOLT CARRIER GROUP

Cocking: As the bolt carrier group moves rearward, it returns the hammer to the cocked position, causing the trigger sear to re-engage the hammer notch.

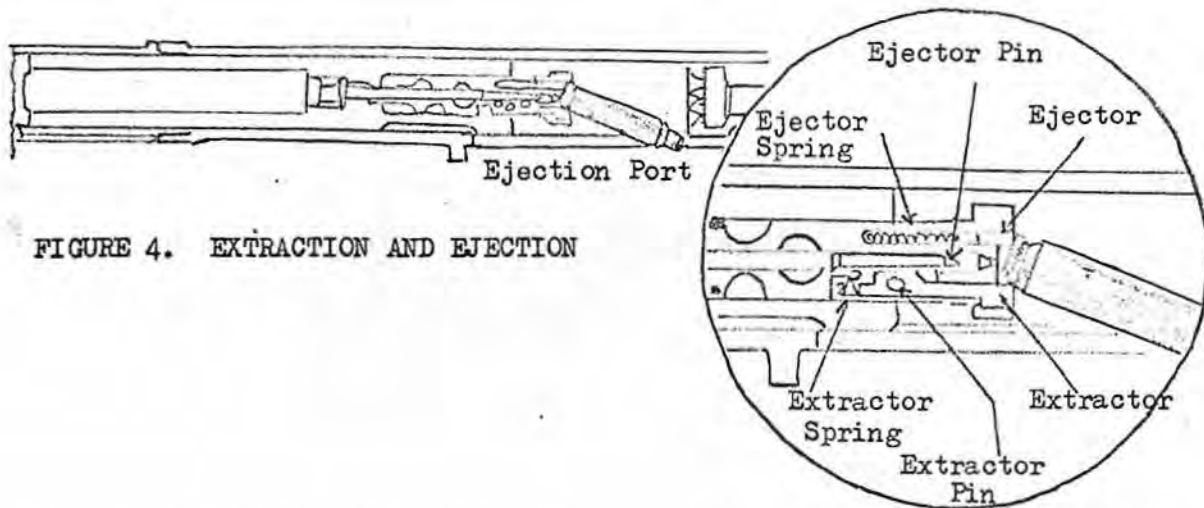

FIGURE 4. EXTRACTION AND EJECTION

Extracting: As the bolt and bolt carrier move rearward, the extractor on the bolt withdraws the expended cartridge from the chamber.

Ejecting: The ejector, under pressure in the face of the bolt, throws the cartridge out of the ejection port as the case clears the receiver.

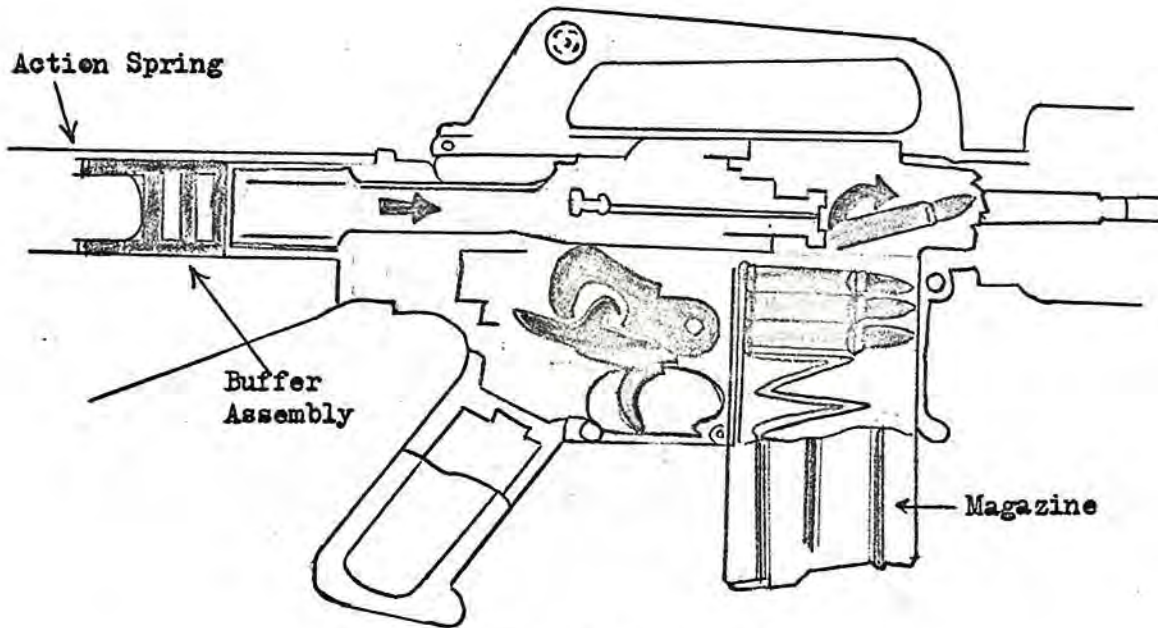

FIGURE 5. FEEDING

Feeding : The rearward movement is arrested by the buffer assembly and action spring. The action spring then forces the bolt carrier back toward the chamber.

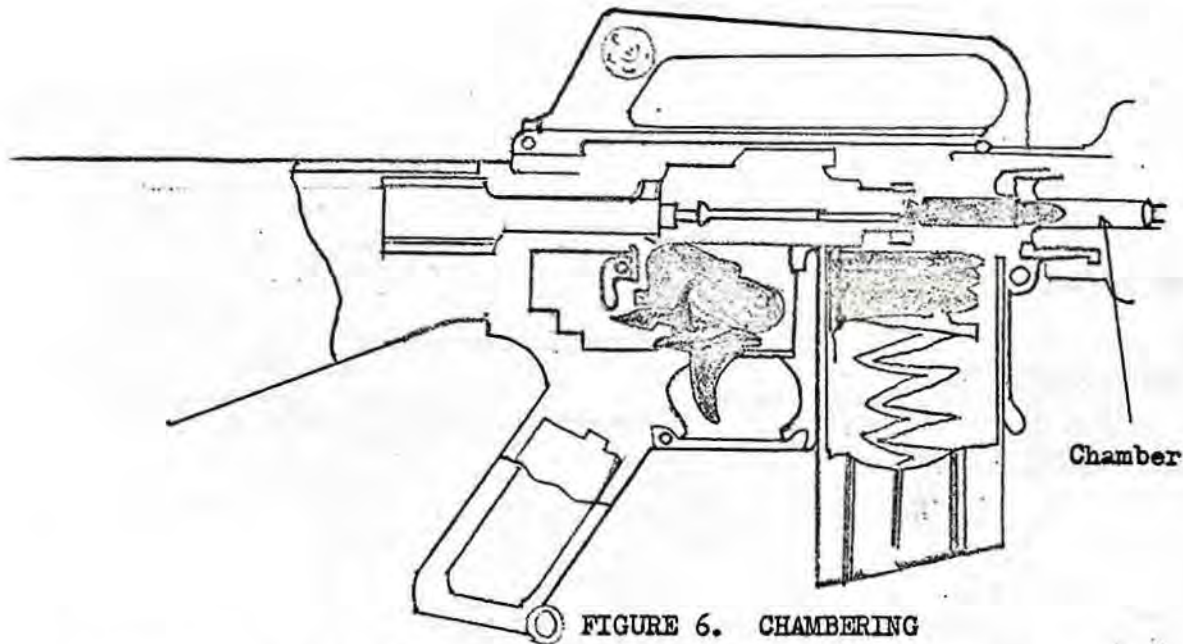

FIGURE 6. CHAMBERING

Chambering: On its forward movement, the face of the bolt forces a round out of the magazine (feeding) and thrusts it into the chamber.

Locking: As the bolt lugs enter the barrel extension, the ejector is depressed between the face of the cartridge and the bolt and the extractor snaps into the extractor groove of the cartridge. As the bolt carrier enters the final $\frac{1}{2}$ inch of its closing stroke, the bolt carrier cam track rotates the bolt and locks it into the barrel extension. This completes one entire cycle of operation and the weapon is ready to be fired again. The cycle is the same for semi or full automatic fire.

The disconnect prevents the rifle from firing fully automatic when the selector is set on SEMI position. When the trigger is pulled, the disconnect is rotated with the trigger by the action of the disconnect spring. During the cocking process, the hook of the disconnect engages the upper inside notch of the hammer as shown in Figure 7. This holds the hammer back and prevents a second shot.

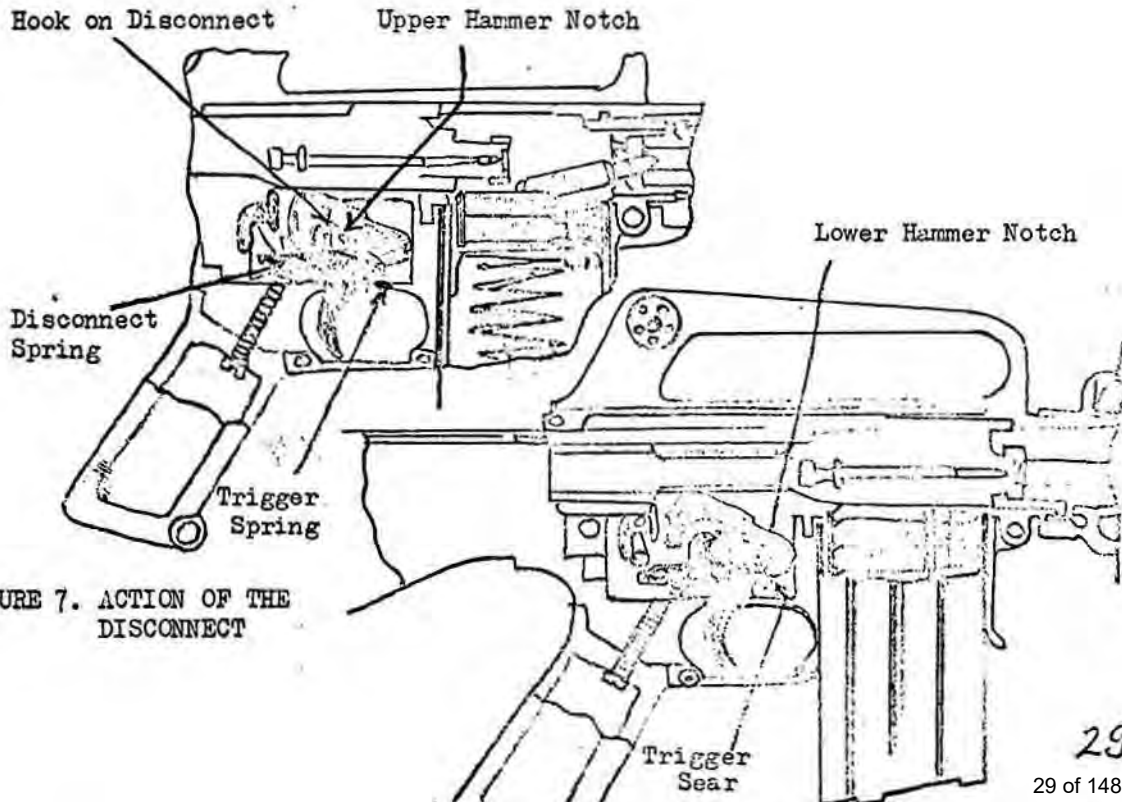

FIGURE 7. ACTION OF THE DISCONNECT

When the trigger is released, the trigger spring causes the trigger to return to its normal position, carrying the disconnect backward with it. Just before the disconnect hook actually releases the hammer, the trigger sear is moved in front of the hammer notch and the hammer drops from the disconnect to the trigger sear. The weapon is now ready for a second shot. When the weapon is fired with the selector on AUTO position, the hammer is moved into the cocked position by the belt carrier. The automatic sear engages the top outside notch in the hammer (Figure 8) The sear holds the hammer in a cocked position until the belt carrier, in its forward movement of locking strikes the upper edge of the automatic sear. This causes the automatic sear to rotate on its pivot and releases the hammer. The hammer moves forward and fires the next round. The cycle repeats and firing continues until the magazine is empty or the trigger is released.

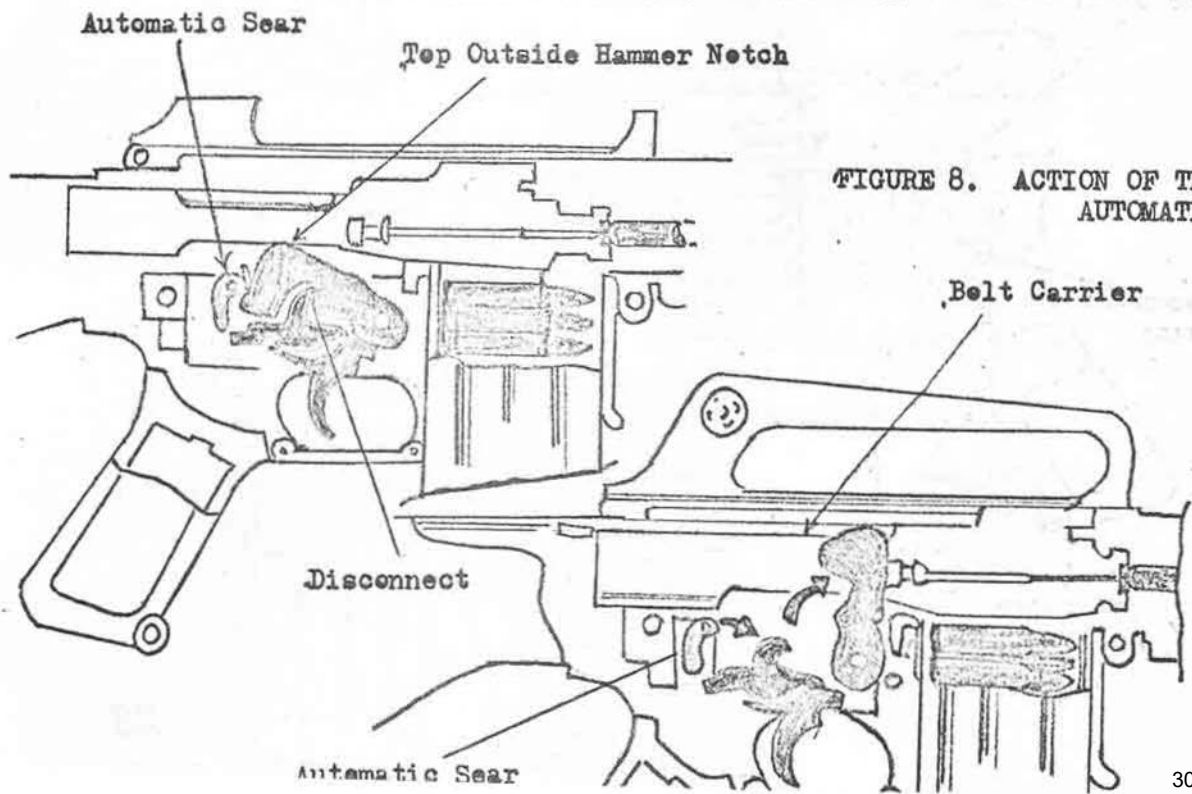



FIGURE 8. ACTION OF THE AUTOMATIC SEAR

ASSEMBLY/DISASSEMBLY AND FUNCTION CHECK

The M-16 Rifle must be cleaned as soon as possible after each days use, whether it has been fired or merely exposed to conditions of dirt and grime. Your life and the life of others may well depend on the care you give your rifle. It is necessary for you to know how to assemble and disassemble your assigned weapon, and then to perform the function check to insure that the weapon is operating properly.

No special equipment is needed to field strip the M-16 Rifle. All that is required is to have a small pointed object, such as key, nail file, etc., or even the point of a cartridge. The following sequence of diagrams will illustrate the method of field-stripping. The first step in the field stripping of any weapon is to make the weapon safe for handling by properly clearing it.

NOTE: The number in the upper left hand corner of the field-stripping diagrams gives the sequence of operation or disassembly.  1

The number in the lower right hand corner gives the sequence of assembly.  2

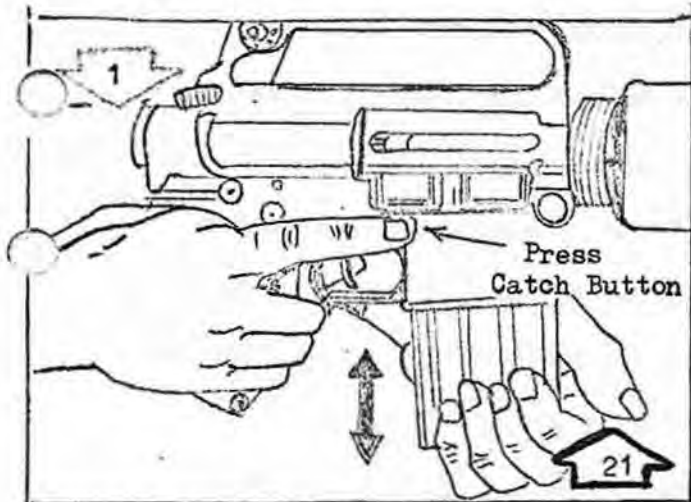

REMOVE/INSTALL MAGAZINE

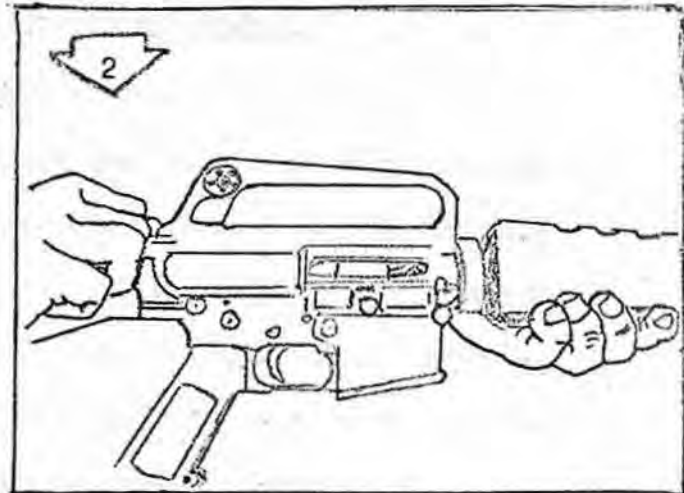

OPEN BOLT AND INSPECT CHAMBER

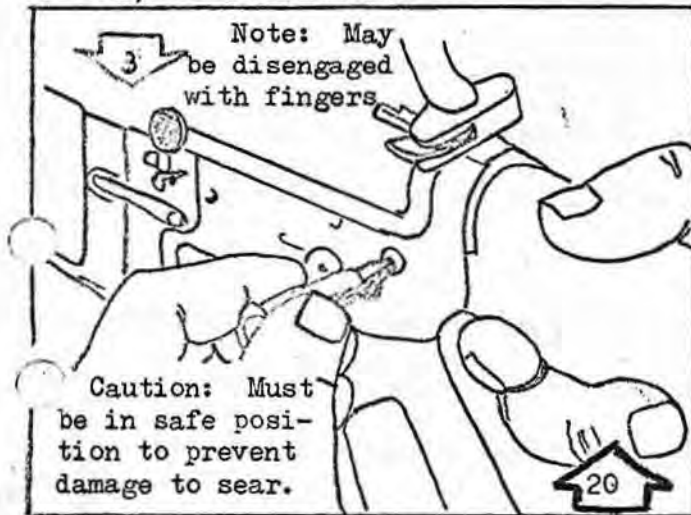

DISENGAGE/ENGAGE TAKE DOWN PIN

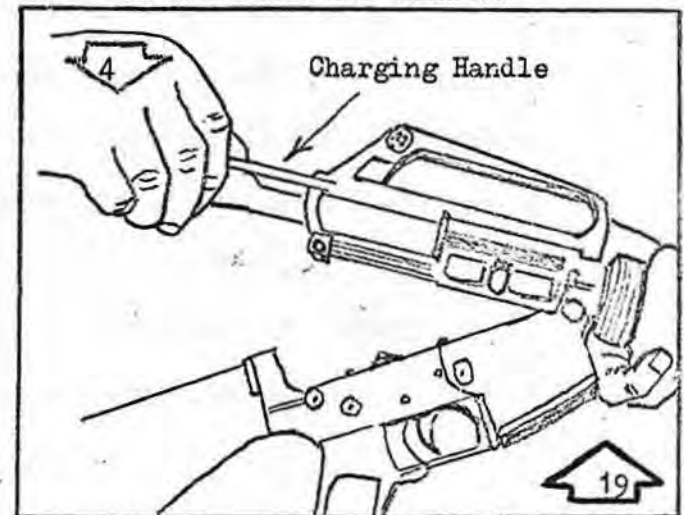

WITHDRAW/INSERT CHARGING HANDLE AND BOLT CARRIER AND KEY ASSEMBLY

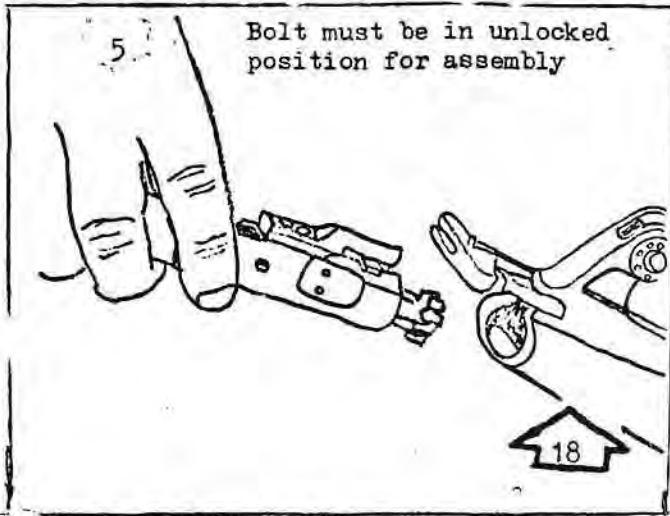

REMOVE/INSTALL BOLT CARRIER AND KEY

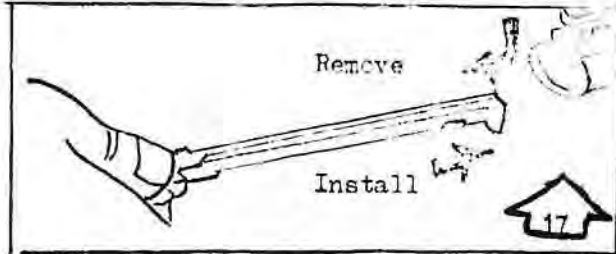
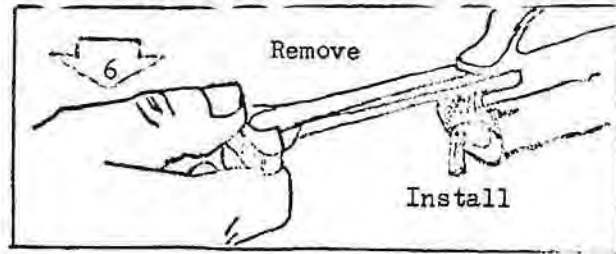

REMOVE/INSTALL CHARGING HANDLE

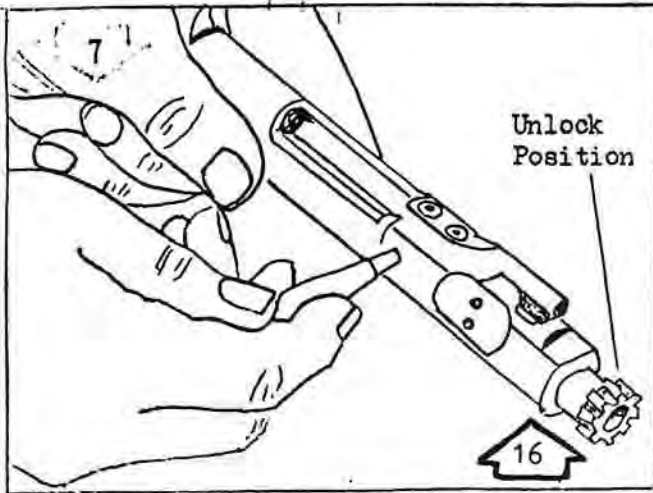

REMOVE/INSTALL FIRING PIN RETAIN PIN

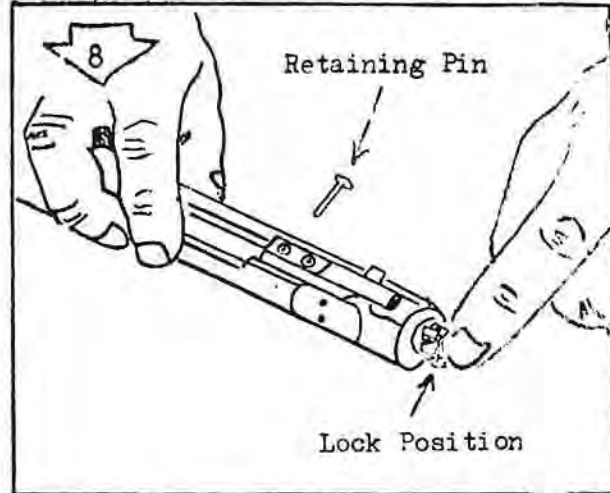

PLACE BOLT IN LOCK POSITION

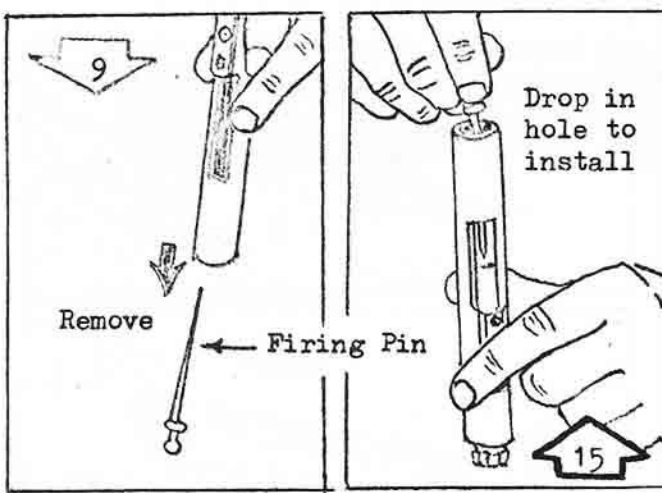

REMOVE/INSTALL FIRING PIN

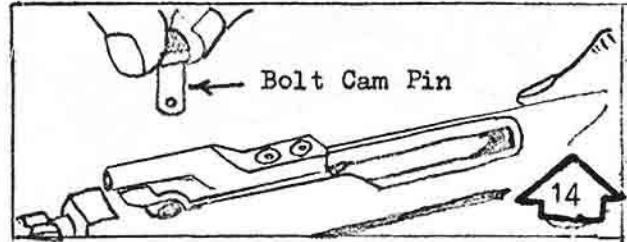
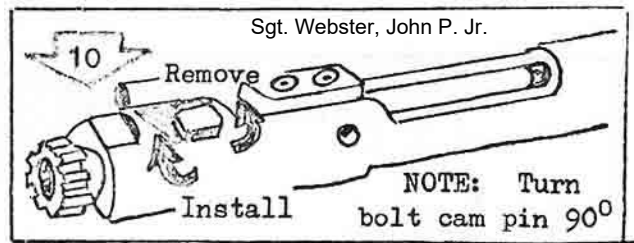

REMOVE/INSTALL BOLT CAM PIN

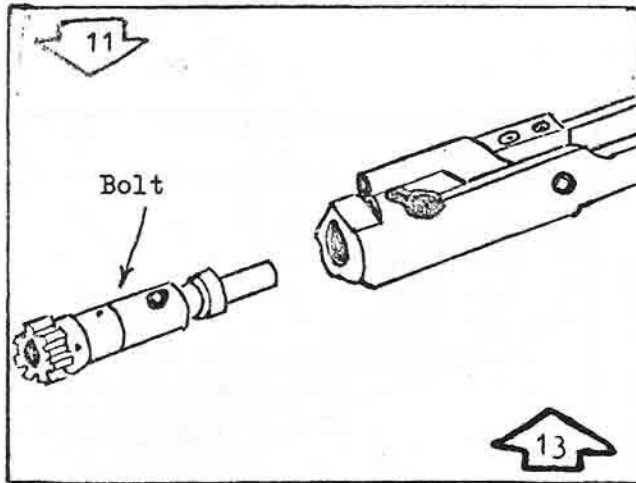

REMOVE/INSTALL BOLT FROM BOLT CARRIER KEY

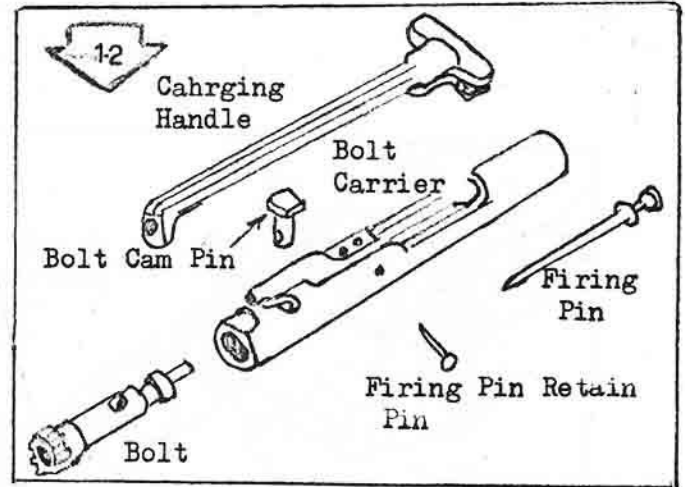

BOLT CARRIER GROUP PARTS

M-16 RIFLE

CARE AND CLEANING

The materials necessary to clean the M-16 Rifle consists of a cleaning red, patches, oil, cleaning solvent and a brush.

Cleaning and Lubrication Before Firing:

Visually inspect the bore and chamber for condition and obstructions. Clean by pushing clean, dry patches through the bore (from the chamber to the muzzle) to remove all dirt and oil. Remove any oil or dirt from the outer surface of bolt and bolt carrier with clean dry patches or rags. Place a drop of oil in each of the two holes of the bolt carrier to lubricate the bolt (piston) rings and in the tip of the bolt carrier key (See Figure 11).

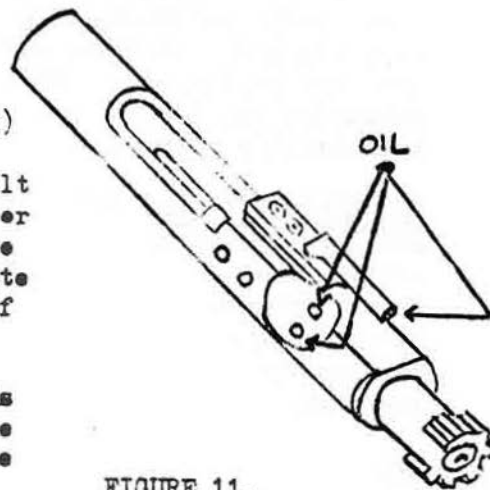

Cleaning and Lubrication After Firing: As soon as practical after firing, the rifle will be cleaned, and for three successive days thereafter.

Cleaning the Bore and Barrel Extension:

Attach the wire brush furnished with the cleaning red, dip it in the bore cleaner, and brush the bore thoroughly. Brush the bore from chamber to muzzle using straight through strokes. DO NOT USE A SCRUBBING ACTION OR REVERSE STROKES IN THE BORE. Push the brush through the bore until it extends beyond the flash suppressor. Continue until the bore is well covered with cleaner. Remove the brush from the cleaning red, and dry the bore by pushing clean, dry patches through the bore. Continue changing patches until they come out clean and dry.

FIGURE 11.
LUBRICATION POINTS
BOLT CARRIER GROUP

To clean the locking lugs of the barrel extension and the chamber area, use a long haired brush soaked in bore cleaner. After cleaning, lubricate the bore with a lightly oiled patch to prevent corrosion and pitting. Thoroughly oil the lugs in the barrel extension.

Cleaning the Belt Carrier Groups: Disassemble the belt carrier group as explained earlier. Wash all external surfaces with a cleaning patch saturated in solvent cleaning compound. Use a small brush (an old toothbrush works extremely well) dipped in bore cleaner to scrub all carbon deposits and dirt from the locking lugs of the belt. Brush the face of the belt paying particular attention to the area under the face of the extractor and to the area behind the rings. DO NOT attempt to remove discoloration caused by heat. When dry, lubricate as shown in Figure 11.

CLEANING UPPER AND LOWER RECEIVER GROUPS: Carefully wipe all dirt from the external surfaces of the upper receiver, paying particular attention to the keyway groove in the top of the upper receiver. On the lower receiver group, wipe any particles of dust from the trigger mechanism with a clean patch or brush. Thoroughly oil all movable parts, pins, etc., paying particular attention to the safety selector lever. This part should be operated several times after oiling.

Belt Carrier Group Reassembly: Reassemble the belt carrier group by reversing the procedures outlined for disassembly. There is a milled ridge at one end of the belt cam pin hole in the belt that permits the cam to be inserted in the belt in only ONE DIRECTION. NOTE: The extractor must be at approximately the one o'clock position. If the belt is not positioned properly, rotate the belt in the belt carrier until the proper cam pin hole aligns with the belt carrier cam slot so that the belt cam pin can be inserted.

Replacing the Bolt Carrier Group and Charging Handle: Insert the charging handle in the upper receiver by mating the lugs in the handle with the slots in the upper receiver. Push the charging handle up into the slots of the upper receiver, and move the handle forward until it extends only about three inches.

With the bolt carrier group in the left hand, grasp the bolt locking lugs with the right hand and pull forward, allowing the bolt to rotate, until the bolt cam pin is in its full forward position.

While holding the rear of the receiver elevated above the muzzle, start the bolt locking lugs into the receiver with the rear of the bolt carrier held at a downward angle; rotate the rear of the bolt carrier upward while moving it into the receiver, at the same time guiding the bolt carrier key into the slot of the charging handle.

Push the bolt carrier group toward the muzzle until it locks into the barrel extension and the charging handle is locked into its forward position.

Locking Upper and Lower Receiver Groups: Cock the hammer if it is not cocked. Make sure the safety lever is safe. Close the weapon and press the takedown pin.

M-16 FUNCTION CHECK

CLEAR WEAPON

1. Locks bolt to rear
2. Places Safety "ON".
3. Visually checks chamber
4. Allows bolt to go Forward.

Pull trigger while safety is "ON".

Move selector lever to "SEMI" and pull trigger.

Hold trigger to rear and re-cock weapon.

Release trigger and listen for audible click from disconnecter.

Move selector lever to "AUTO" while weapon is still cocked, pull trigger, allow hammer to fall.

Held trigger to rear and re-cock weapon, allow bolt to snap forward.

Release trigger and pull again, hammer should not fall.

CLEAR WEAPON

1. Lock bolt to rear.
2. Place safety "ON".
3. Visually check chamber.

7.62mm M-60 MACHINE GUN

1. DESCRIPTION

The M-60 Machine Gun is a belt fed, gas operated, air cooled, automatic weapon. Ammunition is fed into the gun by means of a disintegrating metallic link belt. A pouch to hold a hundred round belt may be attached to the left side of the receiver. The weapon has a quick change barrel with fixed head space. It has a cocking handle to manually cock the weapon in the open belt position. Once cocked, the energy needed to operate the gun is provided by the trapped gases from the previously fired round.

2. NOMENCLATURE AND ACTIONS OF PARTS

a. The Six Major Groups: The M-60 machine gun is composed of six major groups: (1) the barrel assembly, (2) stock group, (3) buffer group, (4) operating group, (5) trigger housing group, (6) receiver group. (See following section on Disassembly/Assembly).

b. Bipod Mount: The bipod mount is an integral part of the barrel group. It is not removed at unit level. The bipod yoke fits around the barrel and is held in position by the flash suppresser.

c. Tripod Mount: The M-122 Tripod Mount consists of the tripod assembly, the transversing and elevating mechanisms and the platform and pintle assembly.

d. Safety: The safety lever is located on the left side of the trigger housing group. If the lever is on the "SAFE" (S) position, the belt cannot be released to go forward nor can it be pulled to

the rear. If the safety lever is in the "FIRE" (F) position, the bolt will go forward when the trigger is pulled; the bolt can also be pulled to the rear by pulling the cocking handle rearward. Each time that the bolt is manually pulled to the rear, the cocking handle must be pulled to the rear.

3. LOADING THE MACHINE GUN

To load the M-60 Machine Gun, the bolt must be pulled to the rear and the safety on the "S" position. The cover is raised and the first round of the belt is placed in the groove of the feed tray. The cover is then closed and the safety lever is placed in the "F" position. The weapon is then ready to fire.

4. MALFUNCTIONS AND STOPPAGES

A malfunction is a failure of the gun to function satisfactorily. Defective ammunition or improper operation of the gun by a student is not considered a malfunction. Two of the more common malfunctions of the M-60 machine gun are "sluggish operation" and "runaway gun". Students will be taught how to perform immediate action drills on the machine gun while on the firing ranges to know what actions to take to overcome the basic causes of malfunctions. A stoppage is any interruption in the cycle of operation caused by faulty action of the faulty ammunition or gun itself. Stoppages are classified by the relationship to the cycle of functioning of the weapon.

All students will receive extensive training in the necessary immediate action drills required to get their weapon functioning properly again after experiencing a stoppage.

7.62MM M-60 MACHINE GUN

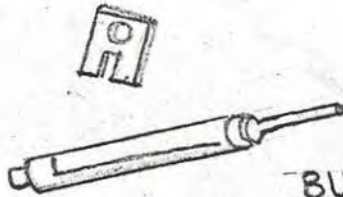

BUFFER GROUP

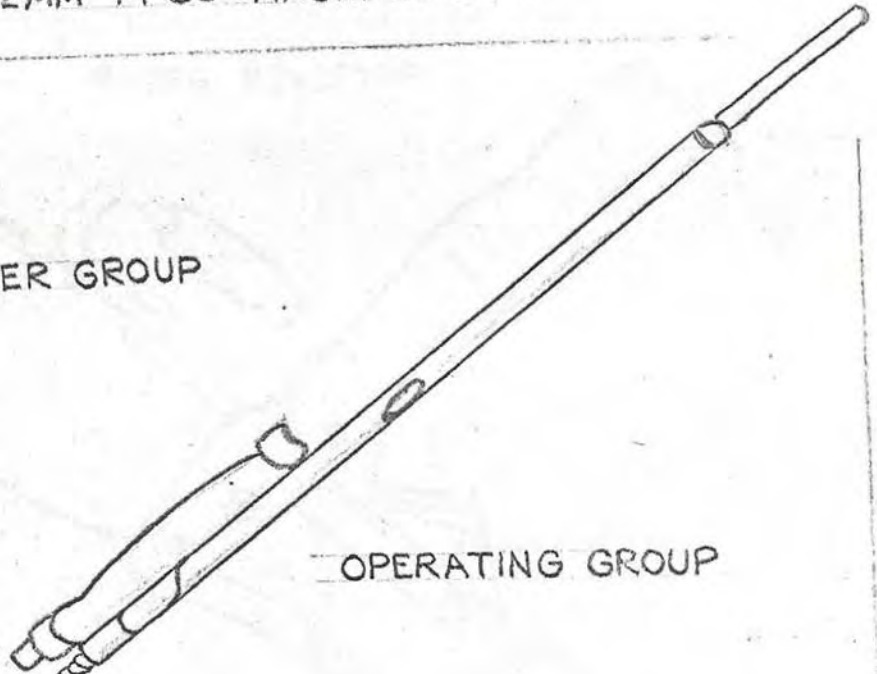

OPERATING GROUP

41

RECEIVER GROUP

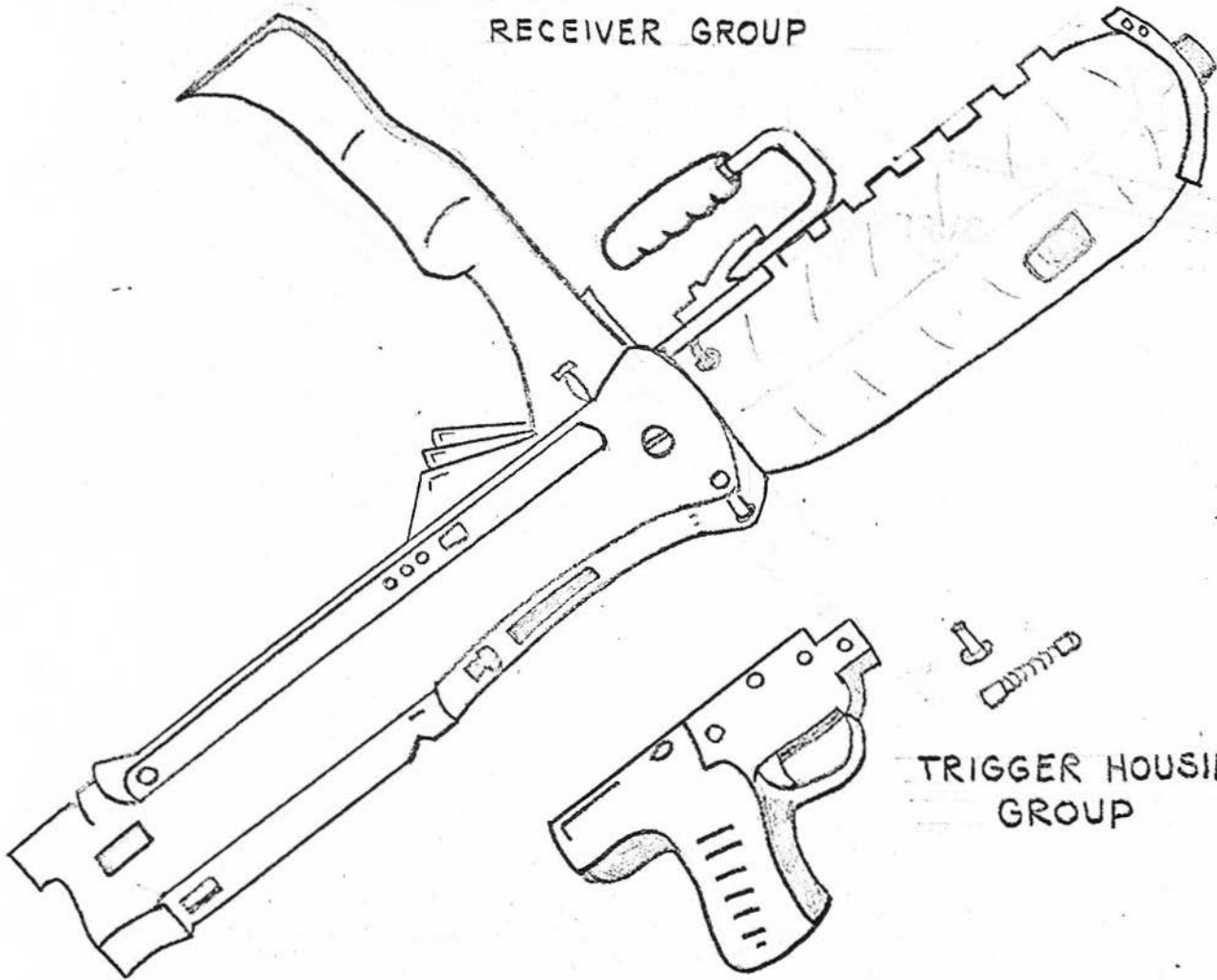

TRIGGER HOUSING GROUP

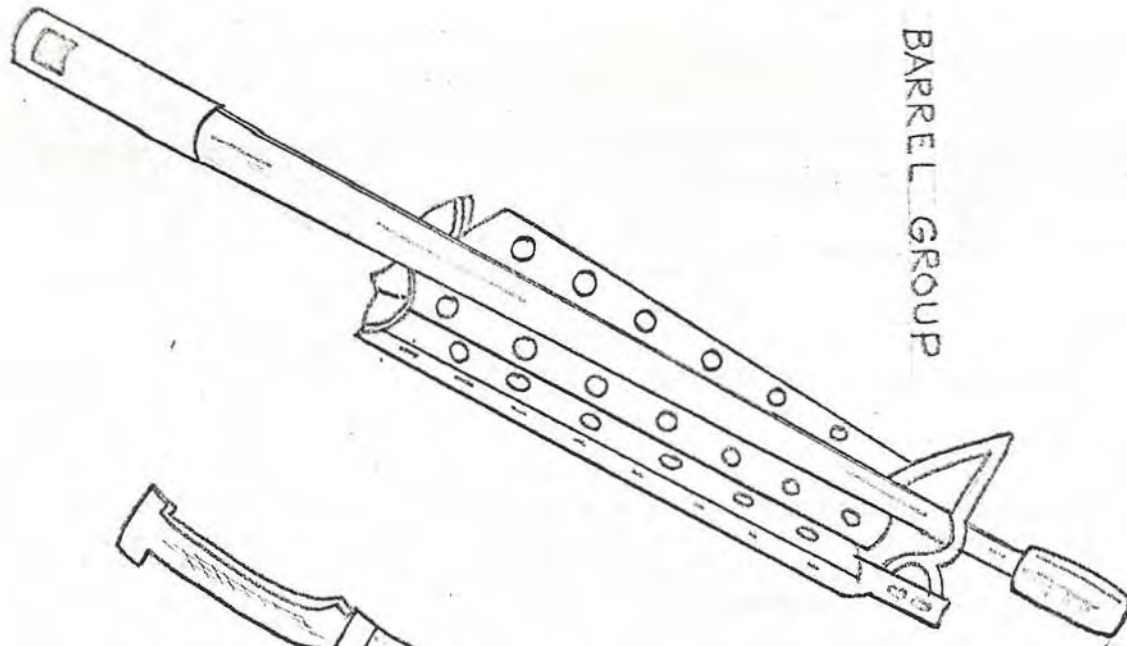

BARREL GROUP

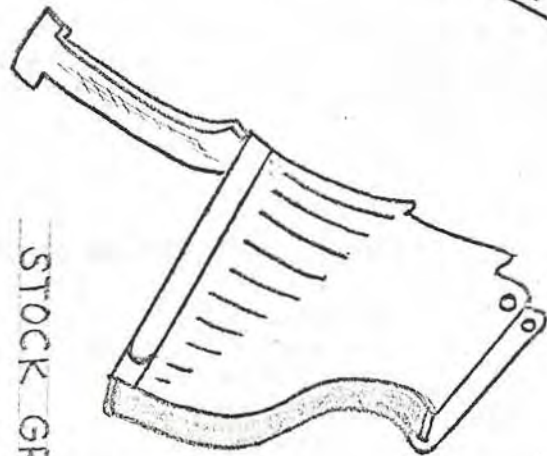

STOCK GROUP

40MM GRENADE LAUNCHER M-148

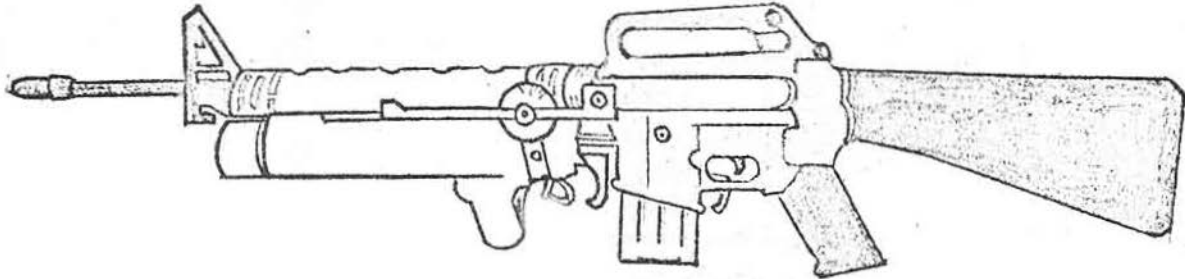

FIGURE 16. M-148 MOUNTED ON M-16 RIFLE

1. DESCRIPTION

The 40mm Grenade Launcher M-148 is a single shot, breech loaded weapon designed for use with the M-16 Rifle. The weapon consists of a launcher assembly, a sight assembly, and a special handguard that replaces the rifles normal handguard when the launcher is attached.

2. OPERATIONAL CHARACTERISTICS

Action.....	Single Shot, Breech Loaded
Sights	
Front.....	Adjustable Post
Rear.....	Adjustable Peepsight
Chamber Pressure.....	3000 lbs psi
Trigger Pull.....	6 to 11 lbs
Muzzle Velocity.....	250 ft per sec
Maximum Range.....	400 Meters (approx)
Maximum Effective Range.....	350 Meters (Area Targets)
Maximum Effective Range.....	150 Meters (Point Targets)
Maximum Safe Range.....	80 Meters (training)
	31 Meters (combat)

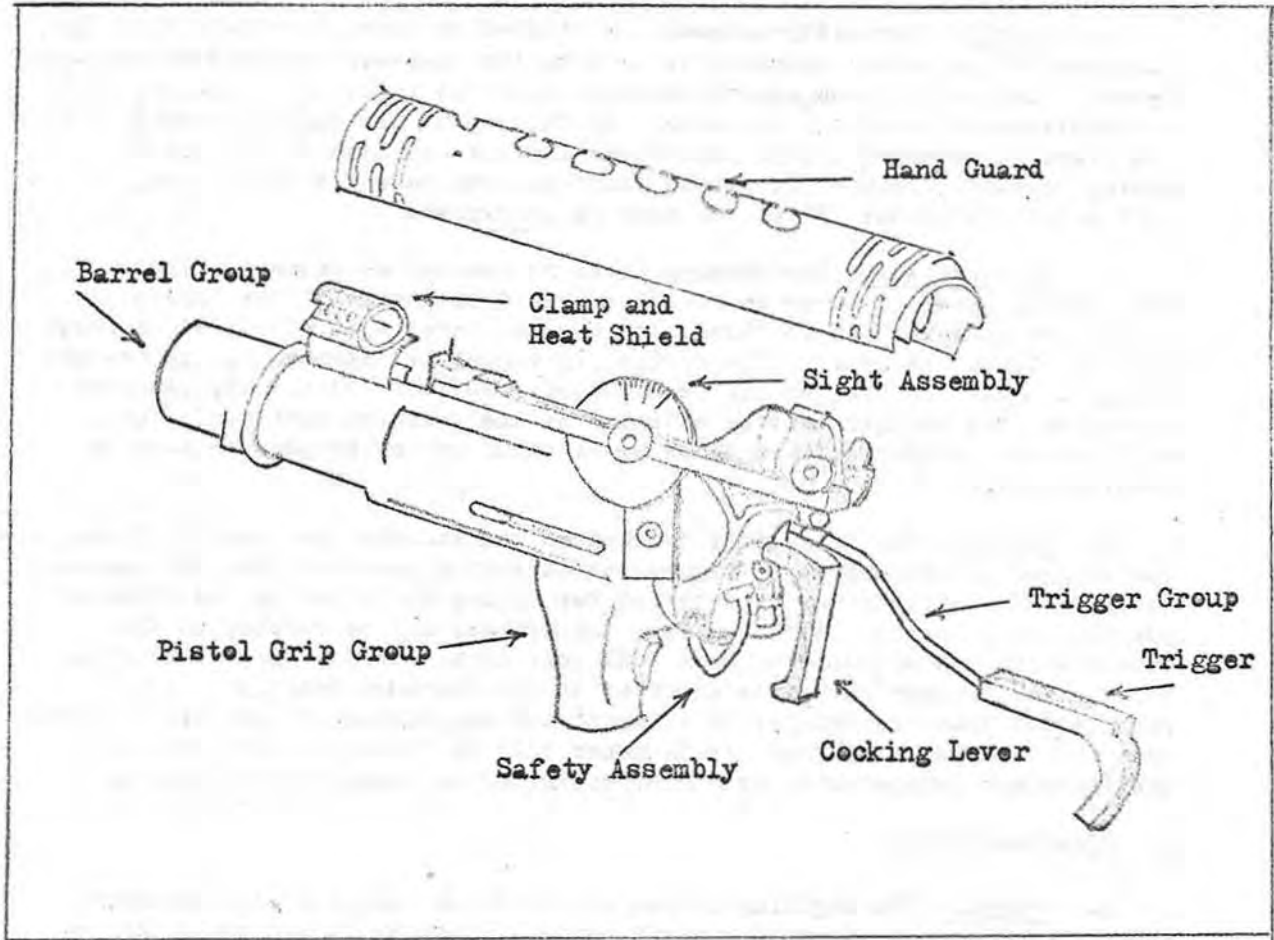

FIGURE 17. LAUNCHER CONTROLS

45

3. LAUNCHER CONTROLS AND SIGHTING EQUIPMENT

a. Safety: The safety assembly is located as shown in Figure 17. The function of the safety assembly is to stop the rearward movement of the sear lever. The safety is engaged by moving it to the right until the letter "F" on the launcher housing is covered. At this point the safety assembly blocks the rearward movement of the sear lever and prevents the firing pin from moving forward. Before firing the launcher, the safety must be moved to the left until the letter "F" on the housing is exposed.

b. Cocking Lever: The cocking lever is located as shown in Figure 17. The cocking lever is screw on to the rearward extension of the firing pin. Before the Launcher can be fired, the cocking lever must be pulled rearward until a "click" is heard. The firing pin cannot be returned to the neutral position until the trigger has been pulled. CAUTION: Before the launcher is cocked, the trigger must be extended to the rearward position. This will prevent accidental fire which would occur if the steps were done in reverse order.

c. Trigger: The trigger is located on the launcher as shown in Figure 17. The trigger is mounted on a trigger bar extending rearward from the launcher housing. The trigger may be extended for firing or placed in the forward position for storage. Additionally, the trigger may be rotated on the extension bar to either the UP or DOWN positions. Before the launcher is cocked, the trigger should be extended to the rearward position. It is recommended that the trigger be extended and maintained in the down position when it is anticipated that the launcher will be fired. In this position, the launchers trigger will not interfere with the trigger of the rifle.

4. SIGHTING SYSTEM

A. General: The sighting system on the M-148 consists of a quadrant sight mounted on an adjustable sight slide. A spring loaded pivot pin in the base of the slide allows the sight to be positioned in the raised,

lowered, forward and rearward positions. In any position of the sight, an adjustment can be made to suit the eye of the person firing by aligning the sight in either of the two holes of the sight slide.

b. Positions of the Sight Slide:

(1) The raised position of the sight affords the grenadier maximum eye and position comfort at all times and ranges and is recommended for use with all firing positions.

(2) The lowered position of the sight slide is designed to afford the grenadier minimum exposure in the prone and foxhole positions. This position, however, is of limited value since the slide interferes with the grenadier's forward hand when firing.

(3) The forward position of the sight slide is best used for stowing of the launcher and is not recommended for aiming purposes.

(4) The rearward position is of limited value for aiming purposes at ranges greater than 200 meters since it causes the grenadier to assume an uncomfortable position and results in canting the weapon during firing.

c. Front Sight Post: The front sight post is located on the forward portion of the quadrant sight. A knob located on the underside of the front sight post allows the post to be adjusted for windage. The windage scale on the front sight is graduated both left and right of the center. Each click moves the strike of the round 2 meters at a range of 200 meters.

d. Rear Sight:

(1) The rear sight is a peepsight mounted on a windage scale. The scale is marked with six graduations both left and right of center. One click on the windage knob will move the strike of the round 1 meter at a

range of 200 meters. One click of the elevation screw will move the strike of the round 2.5 meters at a range of 200 meters.

(2) Range settings are made by aligning the index line on the sight drum base with the appropriate line on the range scale. The range scale is graduated from 50 to 400 meters and is marked at each even hundred by the numerals 1, 2, 3, and 4. The long lines between full 100 meter marks indicate an additional range of 50 meters and the short lines indicate an additional range of 25 meters. To engage targets at ranges where no settings exist on the sight, the grenadier should set the sight at the next higher sight setting and use an adjusted aiming point.

5. OPERATION AND FUNCTIONING

a. Preparation for Firing:

- (1) Check the bore to be sure it is clear and dry.
- (2) Check the launcher to be sure it is properly cleaned.
- (3) Inspect for defective parts.
- (4) Check the firing pin retainer to insure that it is tight.
- (5) Check to see that the front sling swivel has been removed.

b. Functioning:

- (1) Loading: With the barrel in the open position, the cartridge is inserted into the breech.
- (2) Chambering: Chambering takes place when the barrel is closed.

As the barrel is closed the cartridge is held in place by the cartridge retainer and is seated against the face of the receiver when the barrel reaches its full travel rearward.

(3) Locking: The pistol grip pivots upward and engages the spring loaded grip lock plunger in the recess of the grip release, thus locking the barrel in place.

(4) Cocking: The launcher is cocked manually. When the cocking lever is pulled rearward it retracts the firing pin under tension of the firing pin spring, and causes the firing pin to engage a cocking notch on the sear. The cocking notch holds the firing pin to the rear, and the launcher is cocked.

(5) Firing: As the trigger is pulled, the trigger bar pulls the sear lever rearward. The sear lever rotates the sear rearward, disengaging the cocking notch on the sear from the firing pin. When the firing pin is disengaged from the sear, it is driven forward under pressure of the firing pin spring. The firing pin is driven through its aperture in the retainer and strikes the primer of the cartridge. The firing pin is retracted under pressure of a recoil spring in the firing pin retainer.

(6) Unlocking: Unlocking is accomplished by pushing forward on the pistol grip release. The forward movement unlocks the barrel from the receiver.

(7) Extracting: As the barrel is pushed forward, the extractor slides down on a ramp on the rear of the barrel and engages the rim of the cartridge. This holds the cartridge in the chamber and extracts the cartridge from the barrel.

(8) Ejecting: There is no automatic ejector on the launcher. As the cartridge is extracted from the barrel, it falls out of the chamber of the launcher.

6. AMMUNITION

General: The 40mm Cartridge is a fixed type ammunition with a point detonating fuze. The complete round consists of two major assemblies: The cartridge case and the projectile (grenade).

a. Cartridge Case: The aluminum cartridge base is made with an integral propellant retainer. Into this retainer is inserted a thin-walled, brass cup containing the propellant. An aluminum base plug which seals the base of the cartridge case is then pressed and crimped into the propellant retainer. Finally, a M-42 percussion primer is pressed and crimped into the base plug.

b. Types: Currently there are two types of 40MM ammunition issued for use with the launcher, high explosive and practice.

c. Identification: The HE and practice rounds are identical in size, weight and shape. The HE round has a gold colored ogive, while the practice round has a silver colored ogive.

d. Casualty Radius: The HE grenade has an effective casualty radius of 5 meters. The effective casualty radius is defined as the radius of a circle set at the point of detonation in which it may normally be expected that 50% of the exposed personnel will be casualties.

81MM Mortar

1. **DESCRIPTION:** The 81MM Mortar is a smooth-bore, muzzle loading, high angle of fire weapon capable of a high degree of accuracy at ranges up to approximately 4800 meters. The mortar weighs 115 pounds complete with an over all length of 51 inches. The rate of fire is 12 rounds per minute per the first two minutes and 3 rounds per minute sustained fire thereafter. The mortar breaks down into three separate parts; the barrel, the bipod, and the base plate (See figure 15).

a. The barrel consists of a barrel, firing pin, and mount attachment ring.

b. The bipod consists of three assemblies; the leg assembly, the elevating assembly, and the traversing mechanism assembly.

c. The base plate consists of an inner and outer ring assembly which can be separated so as to reduce the load for hand carrying.

2. **FUNCTIONING:** A characteristic of the 81MM Mortar is its simplicity of function. The mortar is fired by inserting a complete cartridge into the muzzle, fin assembly down. The primer of the ignition cartridge strikes the firing pin located inside the base plug. This action sets off the primer which, in turn, explodes the ignition cartridge. The flame from the exploding ignition cartridge ignites the propellant cartridge. The pressure of the gas produced by the burning propellant drives the cartridge up and out of the barrel.

3. **AMMUNITION:** There are three basic types of ammunition used with the 81MM mortar.

51

a. High Explosive (HE): This cartridge is for use against enemy personnel in emplacements and vehicles. The maximum range of this cartridge is 4800 meters.

b. White Phosphorous (WP): Used for screening, for casualty-producing incendiary action, and for signaling. Maximum range is 1500 meters.

c. Illuminating: Used for battlefield illumination and signalling, with a maximum range of 1900 meters.

4. FORWARD OBSERVER PROCEDURES: Anyone who has a means of communications with Fire Direction Center and who can read an azimuth can adjust fire for a mortar section on any target he can see. He does not have to know the location of the mortars and he does not have to compute any data. It makes no difference how far he is off the gun-target line, because FDC makes adjustments to keep the bursts of the observer-target line. To get fire on the target, the observer follows three simple steps.

a. Establishes communications with FDC.

b. Reports the azimuth from his position to the target and attempts to locate the target for the FDC. To locate the target, he can use coordinates, the shift method, or any of the other methods that will inform the FDC where to fire the initial round.

c. If the initial round misses the target, he sends corrections in meters to the FDC that will cause the subsequent round to hit the target.

It is not necessary to be a trained forward observer or a communications expert to observe and adjust mortar fire. However, the adjustment of indirect fire is greatly facilitated by a knowledge of communications procedures and the methods of conducting fire.

(1) The initial fire request is a communication (fire Message) sent by the FO to the FDC requesting fire on a target. It is not a fire command. The initial fire request sent by the FO includes those elements appropriate to the fire mission. The FDC may fire the requested mission or it may decide that there are more important fire missions which should receive priority.

(2) The same general sequence is employed by all indirect fire units that utilize the target grid method of fire control. By following this sequence it is possible for the observer to obtain fire from any mortar unit with the least amount of confusion and in the shortest time.

(3) The following elements are considered when requesting a fire mission and are transmitted in the following sequence:

- (a) Identification of Observer.
- (b) Warning Order
- (c) Reference point or target coordinates.
- (d) Azimuth from Observer to Target.
- (e) Location of Target

53

- (f) Nature of target
- (g) Classification of fire.
- (h) Type of adjustment.
- (i) Type of ammunition.
- (j) Fuse action.
- (k) Control.

FIRE DIRECTION CENTER PROCEDURES

1. ORGANIZATION: The FDC enables the commander to control and quickly mass the fire of his entire unit. The FDC is located at or very near the firing positions so that fire commands may be transmitted to the mortar crew by voice. There are three members assigned to operate FDC; the NCOIC, computer, and radio/telephone operator. Fire requests are reported from all sources directly to FDC where the targets are plotted on the plotting board, M-16. From this board, firing data is prepared by the computer and announced to the mortar crews as fire commands. The FDC can be operated by the computer alone. However, it is desirable to include a radio/telephone operator to allow the computer to concentrate on his primary duties of computing firing data and issuing fire commands.

2. GENERAL DUTIES:

- a. Determine mounting azimuth.
- b. Determine initial firing data.
- c. Enforce priorities of fire.
- d. Determine number of mortars and rounds to be fired.
- e. Compute firing data.
- f. Issue fire commands.
- g. Maintain firing record and ammunition record.

55

3. SPECIFIC DUTIES:

A. NCOIC: The NCOIC controls operations of FDC and approves or disapproves fire missions. He orders execution of prearranged fires and fire missions directed by higher headquarters. Determines priorities of fire, concentration number, type ammunition and fuse to be used, mortar or mortars to adjust and fire for effect, and number of rounds to be fired for effect. Determines and issues the FDC commands to computer, the mounting azimuth, and initial firing data, and provides continuous operations of FDC.

B. Computer: The computer maintains the plotting board and records the firing data during each fire mission. Receives and computes subsequent corrections during a fire mission. Issues fire commands to the mortars.

C. Radio/Telephone Operator: Maintains radio and telephone communications with forward observers, front line troops, and the command post.

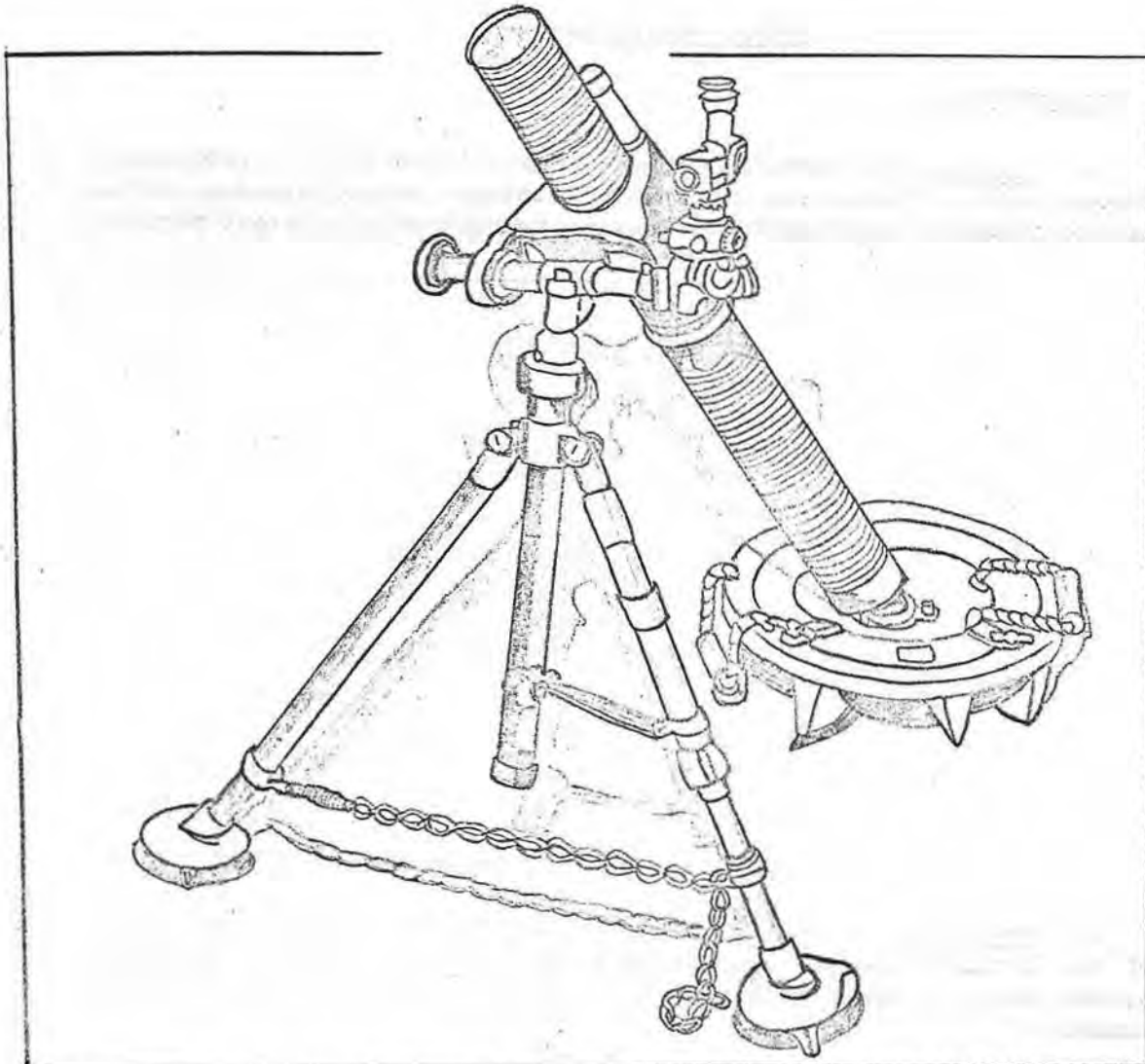

FIG 15. 81MM Mortar M-29, bipod M23A1, Base Plate, M-23.

STARLIGHT SCOPE

1. DESCRIPTION

a. General: The Starlight Scope, Small, Hand-held or Individual Weapons Mounted Device is a portable, battery powered electro-optical battery powered instrument for use in observation of distant objects.

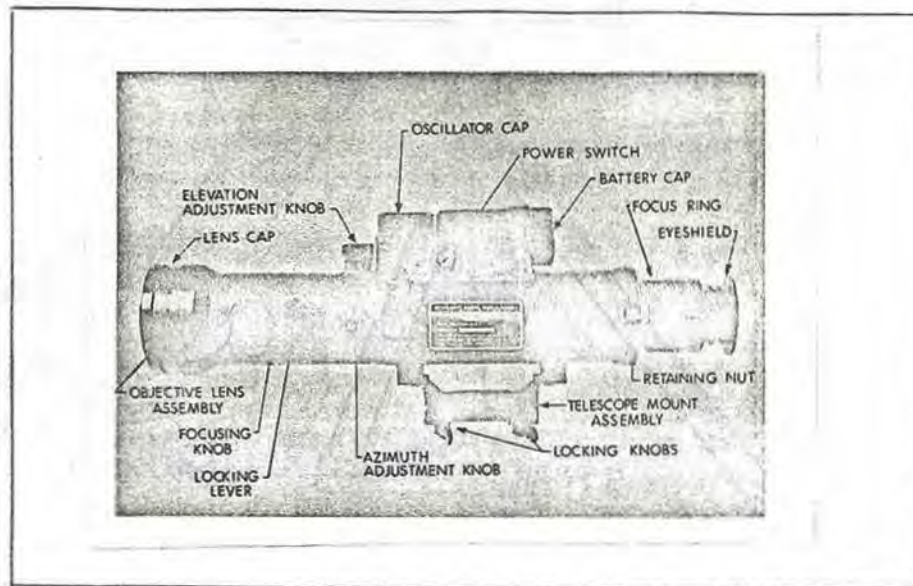

FIGURE 18. OPERATING CONTROLS OF SCOPE

b. Features: Figure 18 shows the essential operating controls of the Starlight Scope. The scope is designed for use on individual weapons such as the M-16 Rifle, M-60 Machine Gun and the M-79 Grenade Launcher.

58

c. The Starlight Scope detects distant and concealed objects by amplifying reflected ambient night-time light from the moon and stars which illuminate the object to such a degree that objects can be viewed through the eyepiece.

d. The Starlight Scope is capable of operation under conditions varying from -65F to +125F at humidity ranging from 0 to 100%.

e. The Starlight Scope is normally contained in a well-protected shipping container, easily carried. When moving the scope from one location to another, such as when patrolling, the scope can be removed from the shipping container and placed into the carrying case that is equipped with shoulder straps for ease of handling and carrying. When removing the scope from the shipping container, care must be used to avoid damage to the scope, which is a sensitive and expensive piece of equipment. Unlatch all six latches on the shipping container before attempting to remove the lid.

2. PREVENTIVE MAINTENANCE INSPECTION

a. SHIPPING CONTAINER: Inspect case for damaged latches, missing parts, identification or instruction plates, liners for dents, damage and dirt. Service as required.

b. STARLIGHT SCOPE: Examine all external parts and surfaces for dust, abrasions, damage, loose or missing parts and ease of operation. Insure that nameplate and eyepiece vernier are readable. Service as required.

c. CANVAS CARRYING CASE: Inspect for dirt, tears, zipper operation and missing eyelets. Service as required.

3. PREPARATION FOR USE

a. Inspecting and Servicing the Equipment:

(1) Place the shipping container down flat on ground or table and raise the latches upward to remove the lid from shipping container.

(2) Remove the canvas carrying case containing the Starlight Scope from the shipping container and set aside.

(3) Open the canvas carrying case and remove the Starlight Scope.

(4) Examine all external parts for dust, cracks, chips, warpage, abrasions, etc. Ensure that all nameplate and eyepiece vernier are readable.

(5) Examine the lens in the eyepiece assembly and objective housing assembly for fogging, condensation or other signs of moisture.

(6) Perform daily preventive maintenance.

4. INSTALLATION OF BATTERY

a. Examine the position of the power switch located behind the protective guard. Ensure that the switch is in the center (OFF) position before installing the battery.

b. Install the battery.

(1) Remove battery cap in counter-clockwise position.

(2) Install battery with plus end (raised end) into main housing.

(3) Install battery cap in clockwise direction into main housing.

5. OPERATING INSTRUCTIONS

The operator must know how to perform every operation of which the Starlight Scope is capable. This section gives instructions for the

starting and stopping of the scope, basic motions of the scope, and the coordination of the basic motions to perform the task for which the scope is designed. Since nearly every job presents a different problem, the operator will vary given procedures to fit the individual job.

a. Starting:

- (1) Mount the scope on the M-16 Rifle, if desired.
- (2) Perform daily preventive maintenance inspection.
- (3) Install the battery.
- (4) Insure power switch is in center position.
- (5) Caution: Always maintain lens cap on objective lens when operating in daylight conditions, due to sensitivity to light.

b. Operation:

- (1) Start the Starlight Scope.
- (2) Rotate the eyepiece focus ring until image being viewed is clear.
- (3) Use the lowest (-) diopter reading on eyepiece to reduce possible eyestrain.
- (4) Rotate focus knob until object being viewed is sharp.
- (5) To use the Starlight Scope, place the power switch to the up position (past the center position).

c. Stopping:

(1) Place the power switch in the center position to stop the scope.

d. Ranging:

The Starlight Scope is equipped with an elevation and azimuth reticle adjustment knobs for adapting the Starlight Scope to the trajectory of weapons use.

6. OPERATION IN DUSTY OR SANDY AREAS

Operation of the Starlight Scope in dusty or sandy areas is not recommended, however, if such operation becomes necessary, the following precautions must be observed.

- a. Avoid pointing the objective lens into the wind, if possible.
- b. Cover as much of the Starlight Scope as possible to prevent damage to the external surfaces.
- c. Keep the metal shipping container closed and the canvas carrying case sealed when not removing or replacing equipment.
- d. The eyepiece lens and objective lens will require frequent cleaning and inspection.

62

THE LENSATIC COMPASS

1. INTRODUCTION

During the course of your training you will be introduced to one of the most important pieces of organizational equipment that you will be issued: The lensatic compass. Since most of the patrolling that you will be doing during your training will be conducted at night in terrain totally unfamiliar to you, it takes little imagination to understand why this valuable piece of equipment will be important to you. The use of the compass will be stressed a great deal during your training, for the value of the compass to the individual airman is comparable to that of his rifle.

2. NOMENCLATURE

The Lensatic Compass derives its name from the magnifying lens mounted in the eyepiece. The case is aluminum and the dial capsule is encased in a silicone rubber cap that automatically seals itself when it is assembled into the compass case. The compass case is about 2 inches long and less than one inch thick when closed. Magnetic azimuths can be sighted through the lens and sighting wire and read accurately to within 2 degrees. Closing the compass automatically lifts the magnet and dial assembly off the pivot, thus protecting the parts from wear when the compass is not in use. The dial of the compass is marked in 5 degrees and 20 mil graduations. Cardinal points and markings on the bezel crystal are luminous for reading in darkness. The north seeking end of the magnetic needle is also luminous. The luminous area in the damping shell also aids in reading in the dark.

3. USE OF THE LENSATIC COMPASS

Sighting with the lensatic compass is illustrated in Figures 20 and 21. It should be noticed that the compass is held level and firm. The slit in the eyepiece, the hairline front sight in the cover, and the target are

b3

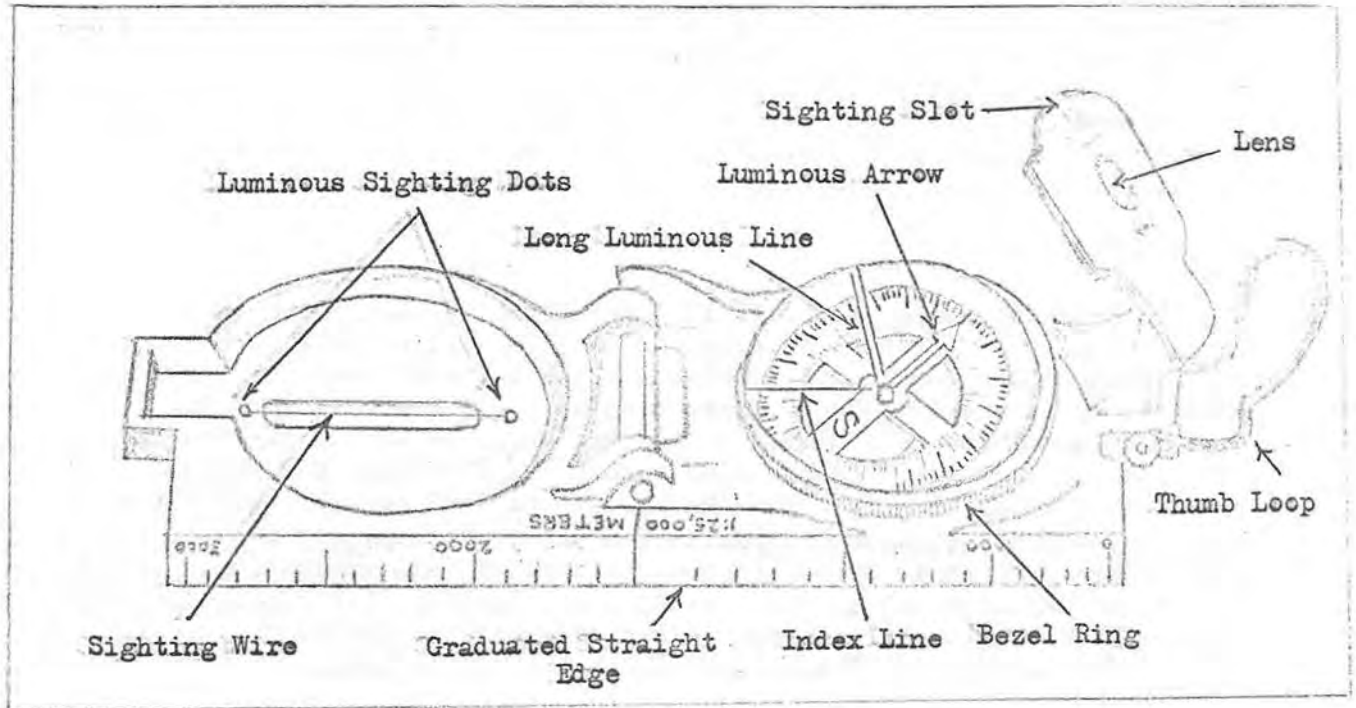

FIGURE 19. LENSATIC COMPASS

64

aligned. When holding this position steady, the azimuth can be read directly by glancing down at the dial through the eyepiece. The numbers on the transparent dial are black and the dial is graduated in mils as well as degrees. The graduated lines for DEGREES are in RED, and it is in these lines that you will be interested throughout your training for the reading of DEGREES, instead of mils, which will be of little use to you during your individual training phase.

a. Compass Precautions: Certain precautions and considerations regarding the care and use of a magnetic compass should be followed. All of these considerations are important because they assure within reason that a compass will work when and where it is needed.

(1) The compass should be handled with care. While the lensatic compass is of sturdy design, the compass dial is set a delicate balance which a shock could damage.

(2) The compass must be closed and returned to its special container when not in use. In this way, it is not only protected from possible damage, but is readily available for use when needed.

(3) When the compass is to be used in darkness, the initial azimuth should be set while light is still available. With this initial azimuth as a base, any other azimuth can be established through the use of the clicking feature of the bezel in conjunction with the 3 luminous dots on the dial.

(4) Compass readings should never be taken near visible masses of iron or electrical circuits. The following are suggested as approximate safe distances to insure proper functioning of the compass:

65

	Yards
High Tension Power Lines.....	60
Field Guns.....	20
Truck or APC.....	20
Telegraph or Telephone Wires.....	10
Barbed Wire.....	10
Machine Gun.....	3
Helmet or Rifle.....	1

Non-Magnetic metals and alloys do not effect compass readings.

b. Night Use: There are a number of lines and dots on the compass that have not been discussed because they are for use at night, when you will be performing the bulk of your compass work. An examination of the face of the compass will disclose that it consists of two glass plates. The outer glass, known as the bezel rotates and makes a clicking sound. Each click represents 3 DEGREES. There are also two luminous lines spaced at a 45 degree angle. The inner glass, that does not move, has a black index line and three luminous dots spaced at intervals of 90 degrees from the index line. On the floating dial, the north seeking arrow and the letters E, S, and W are also luminous. To use the compass effectively at night requires three steps to set the compass. These three steps are:

(1) Rotate the bezel until the long luminous line of the bezel is over the black index line.

(2) Holding the bezel in the left hand, rotate the body of the compass in a clockwise manner the number of clicks required. The number of clicks required may be determined by dividing the value of the azimuth by 3. For example, for an azimuth of 51 degrees, the body of the compass would be rotated 17 clicks clockwise.

(3) Turn the compass until the north arrow is directly under the long luminous line on the bezel. The compass now points at an azimuth of 51 degrees.

bb

c. Methods of Use: The compass, now that it is set, may be used in several ways to travel on the desired azimuth.

(1) With the compass open, held flat in the hand, and keeping the north arrow under the long luminous line, follow the line indicated by the two luminous dots on the cover until arriving at the objective.

(2) Keeping the north arrow under the long luminous line, sight through the compass in the same manner as in the daytime and pick out an object that can be seen and then travel to that object. To assist in sighting the compass at night, luminous dots are provided at each end of the sighting wire.

(3) Should it be so dark that no object can be seen, send another person out along the azimuth line as far as he may be seen, sight on him, and move to his location. Do this until arriving at the objective.

67

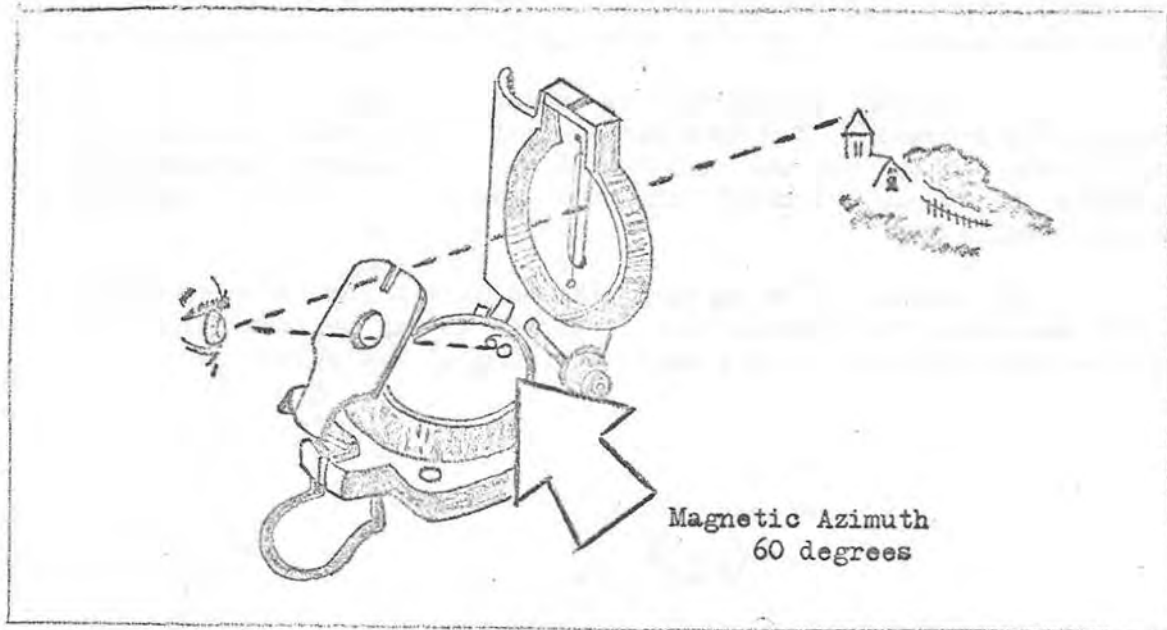

FIGURE 20. PROPER SIGHTING PICTURE

68



FIGURE 21 . COMPASS POSITION FOR SIGHTING

69

TACTICAL SECURITY SUPPORT EQUIPMENT (TSSE)

1. INTRODUCTION

When the 1041st USAF Security Police Squadron (Test) was formed as a unit in September 1966 at Schofield Barracks, its function was two-fold: To train a selected group of Air Force personnel in advanced ground defense tactics, and to train several of these personnel in the operation, function and employment of the newly developed Tactical Security Support Equipment (TSSE), a classified sophisticated system of intrusion detection devices developed for use in detecting enemy presence and movements in combat areas. During the operational test phase at Phu Cat Air Base, RVN, TSSE was fully field tested by the unit and found to be a successful and useful extension of the senses of the individual ground defense airman.

2. GENERAL CONCEPT

TSSE is primarily designed to be installed on the defensive perimeter of an installation or in areas surrounding critical resources to alarm on any enemy intruders. The capabilities of each system differ, with terrain being the governing factor as to where a particular type of system is employed. All these systems have but one purpose: To alert the installation of enemy activity that threaten its resources. Early detection of enemy activity allows the Reaction Forces to respond to threatened areas and neutralize or repulse the enemy threat.

During the Tactics phase of your training you will be given several hours of general introduction to the types of TSSE employed by this unit. In addition to academic classes on the equipment, you will be given the opportunity to observe the operation of the various devices in the field.

70

3. EMPLOYMENT

TSSE systems vary from light, compact units to systems requiring permanent installation. Properly located, installed and monitored by a trained operator, these devices will readily detect and pinpoint enemy intrusion. Light weight and portable systems are readily adaptable for use on Listening and Observation Posts and Ambushes. Governed by the operators ability, and the systems built in devices, actual and false alarms can easily be distinguished, reducing the possibility of compromise. TSSE incorporated into the security posture of an installation will generally result in definite savings in security police personnel. Although these systems do not form a physical barrier, they do form a protective detection barrier, severely limiting the enemy's ability to bring USAF resources under small arms or mortar fire.

4. TYPES OF SYSTEMS

The types of TSSE systems available are numerous and varied, and this inventory is continuously being expanded as new systems are developed. Systems adopted and evaluated for use within the USAF Installation Security Program fall into the following categories:

- a. Pressure Detection Systems
- b. Magnetic Detection Devices
- c. Listening Devices
- d. Visual Detection Devices

71

THE M-16 RIFLE

1. TECHNICAL DATA

The M-16 is an air cooled, gas operated, magazine fed, shoulder or hip fired, semi or fully automatic rifle.

Maximum Effective Range	500 yards
Maximum Range	2,833 yards
Maximum Rate of Fire	
Semi	45/65 rounds per min
Auto	150/200 rounds per min

2. FUNCTIONING

Each time the weapon is fired, many parts inside the rifle function in a given order. This is known as the "cycle of operation". A knowledge of what happens inside the rifle will help you understand the cause of, and remedy for, various stoppages and malfunctions.

The cycle of operation is divided into eight (8) steps: (1) firing, (2) unlocking, (3) cocking, (4) ~~ext~~ (5) ejecting, (6) feeding, (7) chambering, and (8) locking. Although described separately here, the functioning of the steps occur almost simultaneously. With the selector set for semi-automatic fire, a full magazine, and a round in the chamber, the following cycle of operation takes place each time the trigger is pulled, as depicted in the following pages of diagrams, beginning with Figure One (1).

MOUNTAINEERING TECHNIQUES

1. INTRODUCTION

One important phase of your training that will be introduced during your first week of the tactics phase, is the training that you will receive in the techniques of mountaineering. These techniques include military knot tying, rappeling, and the use of rope bridges in stream crossings. These techniques are all expedients that you will be required to use in the field and on patrols over rough and varied terrain. The basic physical unit in this training is the rope. You will be taught how to care for ropes, how to prepare them for specific uses, and how to tie them correctly to get a specific task accomplished.

2. TYPES AND USES OF ROPES

a. Nylon Rope is most commonly used in rappeling. The rope is $7/16$ inch or 1.1 cm in diameter and is issued in 120 foot or $36\frac{1}{2}$ meter lengths. The actual breaking strength when dry averages 3,840 pounds with a 5% variable factor. Strength is reduced by 18% when the rope is wet or frozen. The stretch factor is 20%.

b. Nylon sling rope is commonly used in 12 foot or 4 meter lengths. It can be the same diameter as the rappel rope or $3/8$ inch diameter with 3,000 lbs breaking strength.

c. Manila Rope will be used in the construction of installations requiring great length. This rope is better than nylon for suspension traverse and rope bridges because it has elasticity. When manila rope is bent sharply, as around a snap link, it loses a portion of its strength in the bend.

3. THE MANILA ROPE

- a. 1/4 " - 550 lbs breaking strength: 150 lb safe load capacity
- b. 1/2 " - 2,650 lb breaking strength: 660 lb safe load capacity
- c. 3/4 " - 5,400 lb breaking strength: 1,350 lb safe load capacity
- d. 1 " - 9,000 lb breaking strength: 2,250 lb safe load capacity

4. CARE OF ROPE

Because the rope is frequently the rappellers lifeline, it deserves a great deal of care and respect. The rope should not be stepped on or dragged on the ground. Small particles of dirt will be ground between the strands and will slowly cut them. The rope should not be in contact with sharp corners or edges of rocks that will cut it. Keep the rope dry as much as possible to prevent rotting. Do not leave the rope knotted or tightly stretched longer than necessary and do not hang it on sharp edges such as nails. When using ropes in installations such as suspension traverse, rope bridges, etc., do not let one rope rub against another. This may cut and burn the ropes. Whenever such installation ropes are wet, tension should be relieved.

5. ROPE MANAGEMENT

Before using a rope, it should be inspected for fraying or cut spots, mildew or rot. If such a spot is found the rope should be whipped on both sides (Figure 22) of the bad spot and then cut.

a. Coiling: One end of the rope is taken in the left hand; the right hand is rung along the rope until both arms are outstretched. The hands are then brought together forming a loop which is laid in the left hand.

This is repeated forming uniform loops until the rope is completely coiled. If there is any tendency for the rope to twist or form figure eights, it may be given a slight twist with the right hand to overcome this. The rope should always be coiled in a clockwise direction. In tying a coil, (Figure 23), a 30 cm long bight is made in the starting end of the rope and laid along the top of the coil. Uncoil the last loop and take a length of the rope thus formed and wrap it around the coil and the bight. The first wrap is made at the open end of the bight in such a manner as to lock itself. Then continue wrapping toward the closed end until just enough rope remains to insert through the bight. Pull the running end of the bight to secure the wrapped rope. A rope properly coiled is from 6 to 8 wraps. The coil can be carried on the rucksack by forming a figure eight and doubling it and placing the coil under the rucksack or over one shoulder and under the opposite arm.

6. TERMS USED IN ROPE WORK

- (1) Bight: (Figure 24(1)) - A simple bend of rope in which the rope does not cross itself.
- (2) Loop: (Figure 24 (2)) - A bend of rope that crosses itself.
- (3) Half-Hitch: (Figure 24 (3)) - A loop that runs around an object in such a manner as to lock itself.
- (4) The running end of the rope is the free end of the rope.
- (5) The standing part of the rope is the static part.
- (6) The lay of the rope is the same as the twist of the rope.

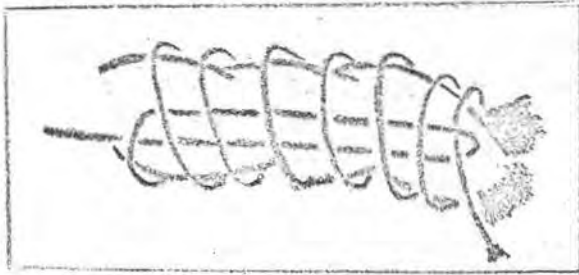

FIG 22. WHIPPED END OF ROPE

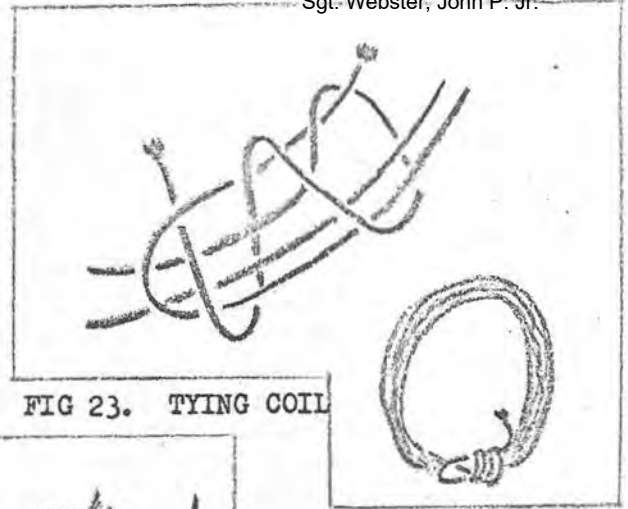

FIG 23. TYING COIL

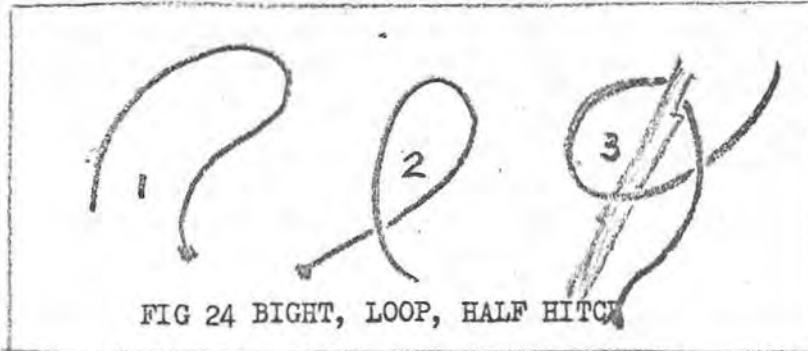

FIG 24 BIGHT, LOOP, HALF HITCH

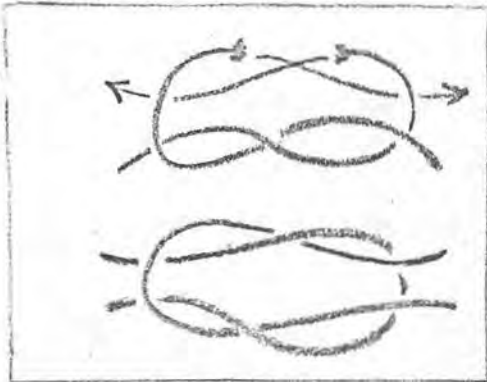

FIG 25. SQUARE KNOT

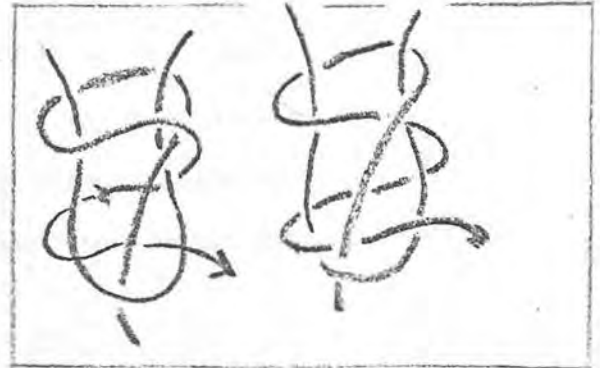

FIG 26. DOUBLE SHEET BEND

76

7. KNOTS

Knots used in rappeling and stream crossing fall into 4 classes.

a. Knots to tie the ends of two ropes together.

(1) Square Knot: (Figure 25). The square knot is used to tie the ends of two ropes of equal diameter together and must be secured by a half hitch on each side of the knot.

(2) Double Sheet Bend: The double sheet bend is used to tie the ends of two ropes of unequal diameter. It can also be used to tie the ends of several ropes to the end of one rope. When two or more ropes are tied to a single rope, the double bends are made with the single rope. (See Figure 26).

b. Anchor Knots: Anchor knots are used to tie the end of the rope to any object. An anchor knot is easy to tie and untie. Care must be used when selecting an anchor knot that will not work itself loose when alternate tension and slack are put on the rope. (Figures 27 and 28). The round turn with two half-hitches and the clove hitch may work loose under these conditions, whereas the bowline will not.

c. Middle Rope Knots: Middle rope knots form a fixed loop or loops in the middle of the rope without using the ends. The Butterfly Knot (Figure 29) is used as the middle man in a roped party and for tightening installation ropes.

(1) The Butterfly will form a single loop.

(2) The bowline on a bight (Figure 30) forms a double loop.

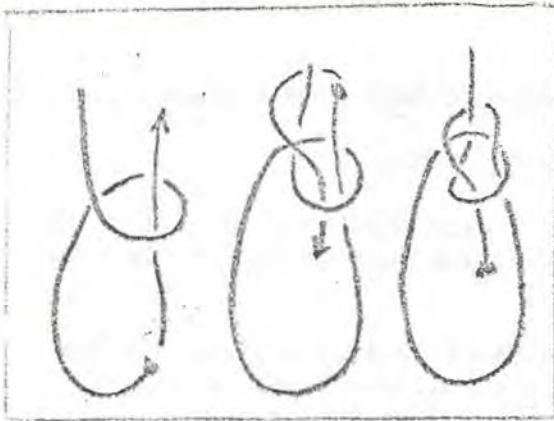

FIG 27. BOWLINE

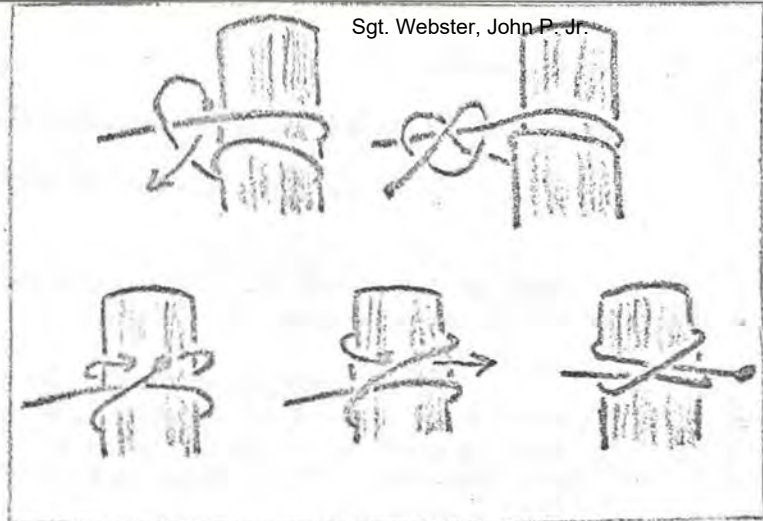

FIG 28. ROUND TURN WITH TWO HALF HITCHES CLOVE HITCH

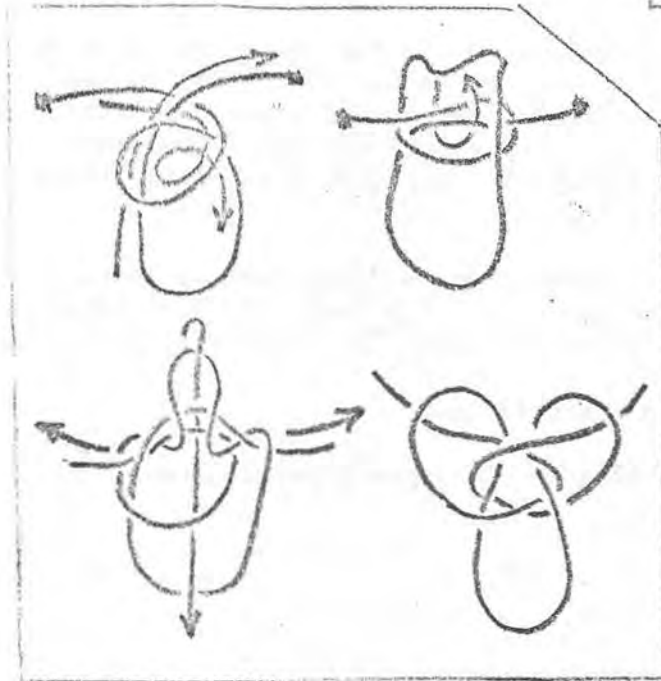

FIG 29. BUTTERFLY KNOT

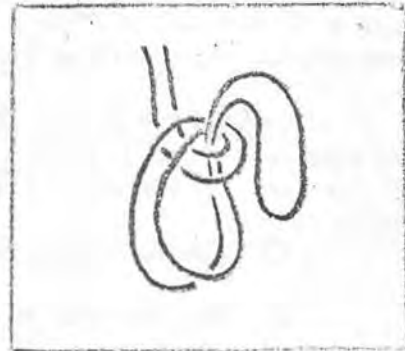

FIG 30. BOWLINE ON A BIGHT

d. SPECIAL KNOTS

(1) Prusik Knot: The prusik knot is tied with a small rope around a large rope; for example, a sling rope around a one inch manila rope in such a manner that the smaller rope will slide on the longer rope if no tension is applied and will hold if tension is applied on the small rope. It is tied with a bight of rope or end of rope. When tied with an end of rope the knot is finished off with a bowline. When tied with the middle of the rope it is finished off with an overhand knot. (Figure 31).

(2) Overhand Knot: The overhand knot is used to make a knotted rope for a hand line and to temporarily whip the end of a rope.

8. ANCHORS

In the setting up, of all installations, the problem of the main anchor is a great one. The ideal situation is to have some good natural objects such as a firmly rooted tree or solid rock nubbin. Since this is not always available, anchors must be made or devised by artificial means. These are called "Deadmen". (Figure 34).

a. Natural Anchors: If a tree is to be used, its firmness is of greatest importance. This is especially true if the installation will be used for any length of time. If rock nubbins can be used, their firmness is again of primary importance. They should be checked for cracks or other signs of weathering that may impair their firmness. Sharp edges should be padded carefully with extra clothing, rags, branches or grass.

b. Artificial Anchors: Artificial anchors in the earth are of two types. The single timber deadman (Figure 34) is the safest type although its construction requires considerable effort. A trench 2 meters long and 1 meter deep and wide enough to work in should be dug at right angles to the direction of the pull. The side of the trench towards the strain should be slanted so that it is a right angles to the pull. Another trench about

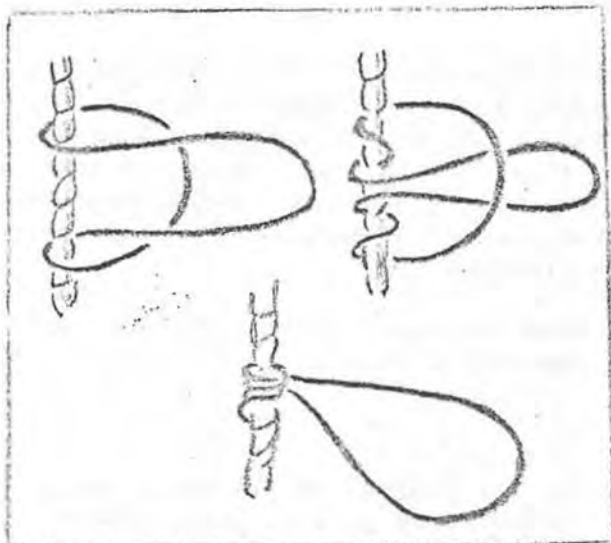

FIG 31. PRUSIK KNOT

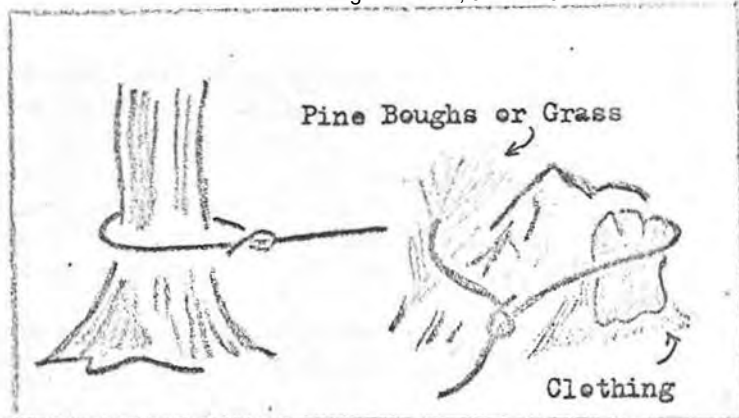

FIG 32. NATURAL ANCHORS, TREE - ROCK



FIG 33. PICKET HOLDFAST

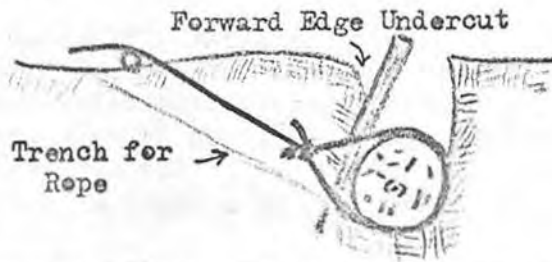

FIG 34. DEADMAN

30 cm wide is dug so that it intersects the trench at a 90 degree angle in the middle. The bottom of this trench should be parallel to the strain and should meet the bottom of the main trench. A log 2 to 3 meters long and 30 cm minimum diameter is normally used for the deadman. The log is then put into the main trench and covered with dirt with the exception of the part adjoining the second trench. If the dirt is not firm, stakes the same length as the depth of the trench should be placed between the deadman and the slanted side in an upright position.

The picket holdfast (Figure 33) is easier to construct but will not hold as much as the deadman. Two meter pickets, 8 cm in diameter are driven into the ground a depth of 1 meter, one behind the other in the direction of the pull. The head of each picket, except the last one, is secured by lashing it to the base of the next one in line. The lashings should be as tight as possible and racked. The pickets should be driven at right angles to the line of pull and the distance between the pickets should be one or two meters. The anchor line is tied to the base of the picket closest to the load.

BRIDGE AND STREAM CROSSING EXPEDIENTS

There are three accepted rope crossing methods, all of which require that an anchor be established on the other side of the stream, crevice or ravine.

a. The One Rope Bridge (Figure 36) is constructed using the 36 $\frac{1}{2}$ meter rope (Manila rope may also be used). Because of the stretch factor in nylon rope, gaps exceeding 20 meters should not be bridged using this method. The rope is anchored with a round turn and two half-hitches and is tied off at the other end with a transport knot. The method used to cross the one rope bridge is known as the horizontal traverse. This traverse can be accomplished by three means:

(1) The Ranger Crawl: The crosser lies on top of the rope with the left instep hooked on the rope and the left knee bent, the right leg

hanging straight to maintain balance. Progress is made by pulling with the hands and arms.

(2) The Monkey Crawl: The crosser hangs below the rope suspended by the hands and heels crossed over the top of the rope.

(3) The Swiss Seat: The same method used in (2) above is employed except the crosser ties a rappel seat and ties into the one rope bridge with a snap link. Of the three methods employed, this is the safer one.

b. Two Rope Bridges: This bridge is constructed similarly to the one rope bridge, except two ropes are used. The ropes are spaced approximately 1.5 meters apart at the anchor points. The bridge is negotiated by sliding the hands palms down along the top rope and the feet along the bottom rope (Figure 35). For safety, a snap link attachment can be used.

c. Hand Line:

(1) If the river is over 20 meters in width, the hand line is used. The most experienced and strongest swimmer is tied into a rope and belayed across the river. The rope is then tied into whatever supports can be found on each bank.

(2) When crossing, it is imperative that each individual stay on the down stream side of the rope as the current has the tendency to pull one under the rope. For safety, a sling rope will be tied around each individual's waist and attached to the handline with a snap link.

(3) Rescue posts are set up at various points down river on both banks. These posts will be manned by personnel equipped with ropes and poles.

(4) The lastman to cross removes the rope from its anchor point, ties himself in, and is belayed across the river from the opposite bank.

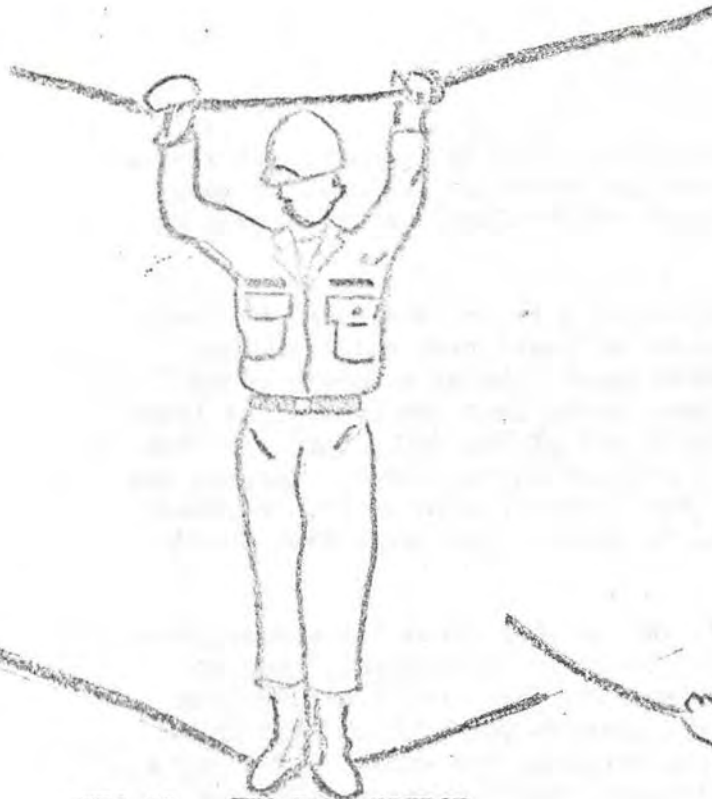

FIG 35. TWO ROPE BRIDGE



FIG 36. ONE ROPE BRIDGE

RAPPELING

1. PURPOSE

The climber with the rope can descend quickly by means of the rappel—sliding down a rope which has been doubled around or anchored to such rappel points as a tree, projecting rock or artificial anchors such as deadmen or pitons.

a. Establishing a Rappel: In selecting a route, the climber should be sure that the rope reaches the bottom or place from which another rappel can be done. The first man down should choose a smooth route for the rope free of rocks. Place loose rocks that the rope might later dislodge far enough back on ledges to be out of the way. Each man down will give the signal "OFF RAPPEL" and straighten the ropes. Inspect the rope frequently if a large number of men are rappeling on it. Climbers must wear gloves for all type rappels to protect the palms from severe rope burns.

b. The Body Rappel: (Figure 37) The climber faces the anchor point and straddles the rope. He then pulls the rope from behind, runs it around either hip, then diagonally across the chest and back over the opposite shoulder. From there the rope runs to the braking hand which is on the same side as the hip the rope crosses; for example, the right hip to the left shoulder to the right hand. The climber should lead with the braking hand down and face slightly sideways. The foot corresponding to the braking hand should precede the other at all times. He should keep his other hand on the rope above him just to guide himself and not to brake himself. He must lean out at a sharp angle to the rock. He should keep his legs well spread and relatively straight for lateral stability and his back straight for this reduces unnecessary friction. The collar should be turned up to prevent rope



FIG 37. THE BODY RAPPEL

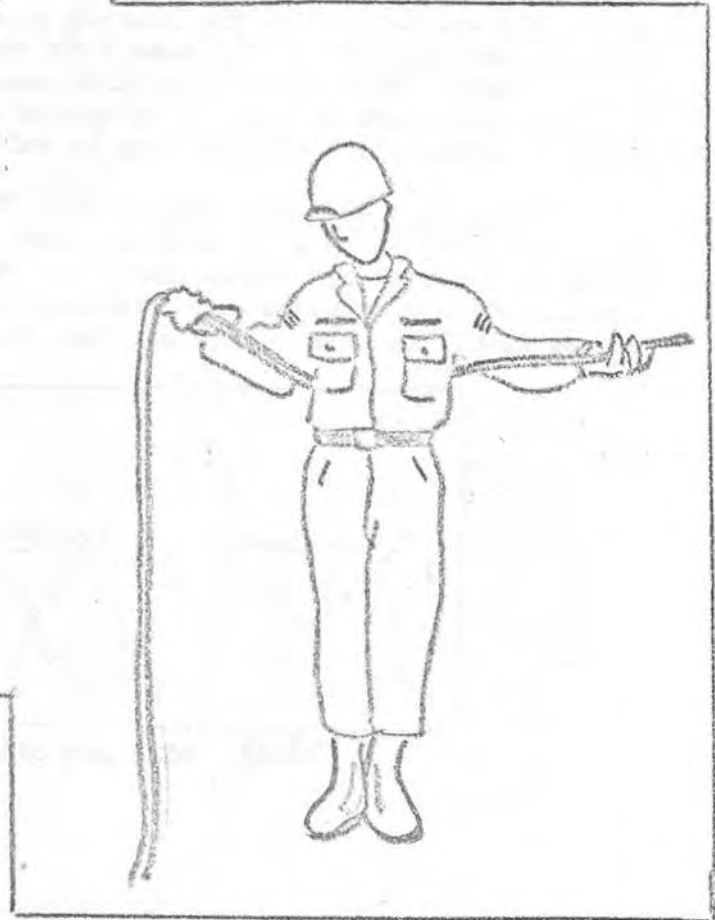

FIG 38. THE HASTY RAPPEL

OK

burns on the neck. Gloves should be worn and any other article of clothing may be used as padding for the shoulders and buttocks.

c. The Hasty Rappel: Facing slightly sideways to the anchor, the climber places the ropes across his back. The hand nearest to the anchor is his guiding hand and the lower hand does the braking. To stop, the climber brings his braking hand across in front of his body locking the rope and at the same time turns to face up toward the anchor point. This rappel should be used only on moderate pitches. Its main advantage is that it is easier and faster than the other methods, especially when the rope is wet.

d. The Seat Rappels: (Figure 39) The seat rappels differ from the Body and Hasty Rappels in that the main friction is absorbed by a snaplink which is inserted in a sling rope seat fastened to the rappeler. This method provides a faster and less frictional descent than the other methods. Gloves should be worn to prevent rope burns.

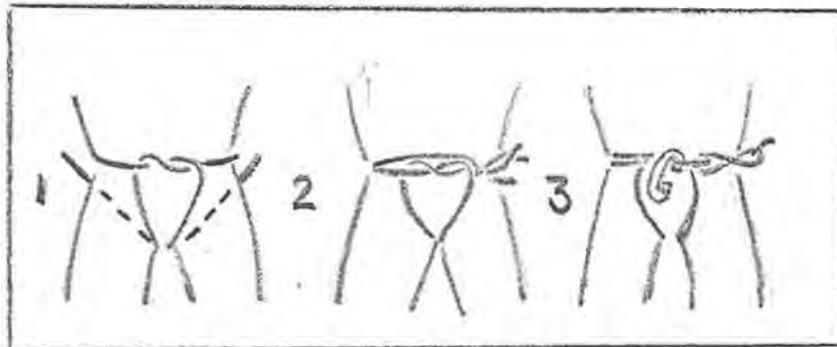

FIG 39. SEAT AND SNAPLINK

(1) Attaching the Seat: The sling rope is placed across the back so that the midpoint (center) of its length is on the hip that is opposite to the hand that will be used for braking. An overhand knot is tied in the front of the body. The ends of the rope are brought between the legs, front to rear, around the legs and over the hips, and tied with a square knot and two half-hitches on the side opposite the braking hand. The snaplink is placed through the single rope around the waist and through the two ropes forming the overhand knot. The snaplink is then rotated one half turn so that the gate is up and opens away from the body.

(2) Seat-Shoulder Method: (Figure 40) In facing the rappel point, the rappeler snaps into the rope which passes up through the snap link. The rope is then brought over one shoulder and back to the opposite hand, left shoulder to right hand. The same techniques are used in the descent as in the body rappel. This method is faster than the body rappel, less frictional and more efficient for men with packs and during night operations.

(3) Seat-Hip Method: The rappeler stands to one side of the rope, (when braking with the right hand on the left, and when braking with the left hand, on the right side), and snaps the rope into the snaplink. (Figure 41). Some slack between the snaplink and the anchor point is taken up and brought underneath, around and over the snaplink and snapped into it again. This results in a turn of rope around the solid shaft of the snaplink which does not cross itself when under tension. When a single rope is used, two wraps around the snaplink are made to increase friction. Facing sideways, the climber descends, using his upper hand as the guiding and his lower as the braking hand. The rope is grasped by the braking hand with the thumb pointing down and towards the body. The braking hand is held behind and slightly above the hip. Braking action is obtained by closing the hand and pressing the rope against the body. The rappeler should lean well out, at an angle from the rock, and make a smooth and even descent. This method is the least frictional and fastest. However, special care must be taken that the rope is snapped correctly into the snaplink to insure against the possibility that the gate may be opened by the rope.

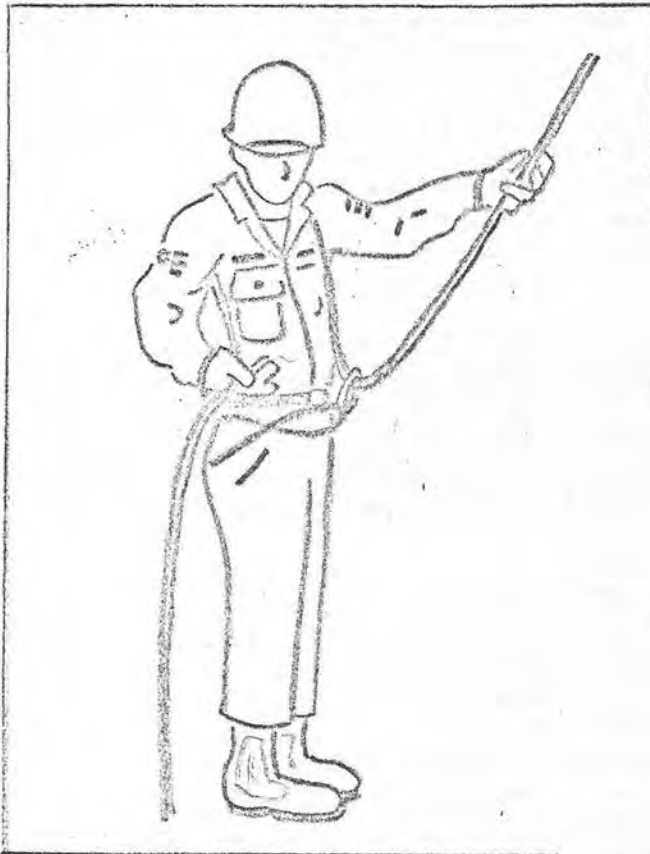

FIG 40. SEAT-SHOULDER RAPPEL

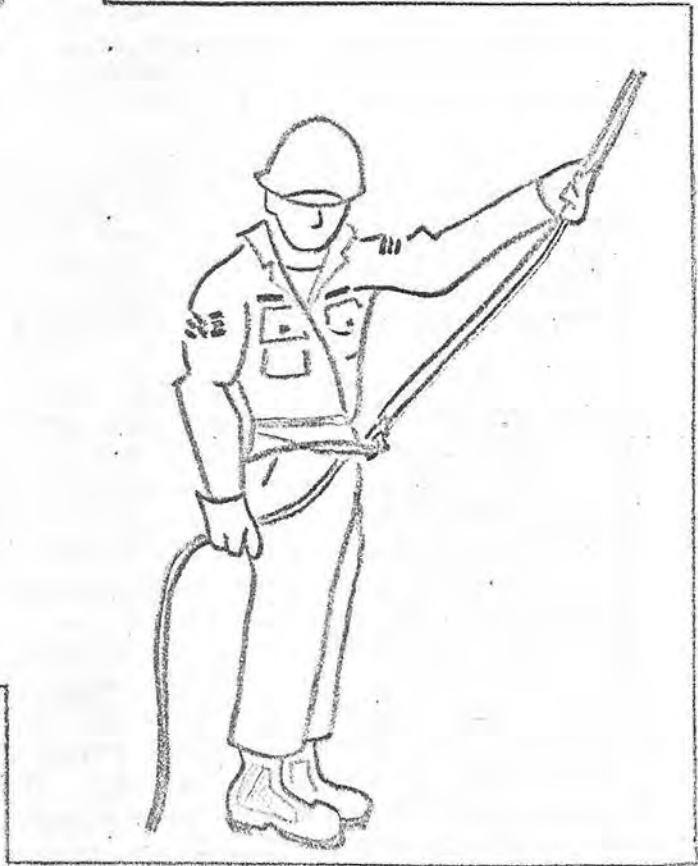

FIG 41. SEAT-HIP RAPPEL

COMMUNICATIONS

1. INTRODUCTION

An important phase of your training in this school will be the introduction to the operation and use of tactical field radios and the combat security radio net. Many students will already have been exposed to using radio nets and equipment in normal Air Force operations. It cannot be too strongly stressed that the procedures used in the operation of day to day administrative nets such as security police, fire department and motor pool dispatch operations, have little in common with the tactical use of radios that you will be taught here in this school. For many students, the communications techniques encountered in this school will constitute a complete re-education in proper radio procedures.

In any combat situation, communications may often play a vital and decisive role in achieving success. However, unless these personnel who operate the unit communications equipment are well trained in proper radio net procedures, no amount of sophisticated radio equipment can ensure proper command, control and coordination. Since each student in this school will be required to operate radio equipment, it is important that maximum effort be given by each student to learn and understand the concept and procedures of tactical radio operations.

2. GENERAL

The main radio station from which command and control functions emanate is known as the Net Control Station (NCS). Normally, for the purpose of combat security squadron operations, the NCS is located as a functional part of the Command Post or Combat Security Operations Center (CSOC). It is the function of NCS to deliver command messages directions and instructions to patrols in the field, and to relay and/or monitor all messages between patrols, sections, and fire support centers. The NCS must also be the coordinating center for all sections operating

in support of each other in field operations, thereby establishing a central control point.

3. NET CONTROL

The authority of the NCS is absolute within its scope of technical control. It opens and closes the net, corrects errors in operating procedures, gives or denies permission for stations to enter or leave the net, and maintains net discipline. The extent of control exercised by the NCS varies according to operating conditions. In a net where experienced operators are passing traffic smoothly, little formal control is required. When the volume of traffic is great and less experienced operators are used, the NCS may be required to exercise firm control to keep the net organized and the traffic flowing in an orderly manner. There are essentially two types of net control operations within an NCS. The free net and the directed net.

a. The Free Net: In a free net, traffic between stations is exchanged without prior permission or coordination with the NCS. Patrols contact action sections directly, and sections in support of each other in the field establish direct radio contact.

b. The Directed Net: In a directed net, stations transmit directly to and through the NCS. Normally, in a unit the size of a combat security squadron with the type of mission assigned to these units, the NCS is a directed net, in order to provide a centralized command and control center.

c. Communications Priorities: When more than one station has traffic to transmit in a directed net, NCS decides which unit has the communications priority. Normally, a patrol or unit operating furthest from NCS has the priority.

4. TACTICAL CALL SIGNS

Call signs are used primarily for establishing and maintaining

communications. They consist of any combination of characters or pronounceable words that identify a communications facility, a command, an authority or a unit. Voice call signs that consist of pronounceable words, such as THIRSTY CANOE or LEVEL DISHES are authorized for radio/telephone communications and should always consist of two words.

5. USE OF CALL SIGNS

For purposes of radio call sign identification within a combat security squadron, each section will probably be given a specific call sign with identifying letter or number shredout for subordinate level identification. For example, (and this is an example only; actual call sign assignment may differ greatly from examples given): The NCS Tactical Call Sign is WHITE ROCK. The Close Combat Flight Headquarters is WHITE ROCK ALPHA, and a specific fire team within that flight may be WHITE ROCK ALPHA ONE. Assignment of tactical call signs in this or a similar manner provides instant identification for any unit in the field calling into the NCS. Additionally, key personnel within the organization are assigned specific tactical call signs to identify themselves on the radio net as command authority when transmitting instructions to the field.

6. RADIO/TELEPHONE PROCEDURE

a. Calls: When communicating in a radio/telephone net, the following call/answer sequence is applied:

(1) "THIRSTY CANOE this is WHITE ROCK, over."

(2) "WHITE ROCK this is THIRSTY CANOE, over."

(3) "CANOE this is ROCK, with an emergency assistance message, can you copy, over."

Note should be taken that once definite call sign identification has been established, one word of the two word call signs may be dropped to expedite the transmissions.

b. Operating Rules: When using radio/telephone, the operator must -

(1) Listen before transmitting to avoid interference with other traffic.

(2) Speak in natural phrases, not word by word.

(3) Speak slowly and distinctly.

7. PRONUNCIATION OF LETTERS AND NUMERALS

To avoid confusion and errors during voice transmissions, special procedures have been developed for pronouncing letters and numerals. These special procedures are the phonetic alphabet and phonetic numerals.

(a) The handouts attached to this section show the phonetic alphabet and prowords used in radio/telephone transmissions. The word that might be misunderstood is spoken, spelled phonetically, and then spoken again. For example: "CRATER, I SPELL - CHARLIE ROMEO ALPHA TANGO ECHO ROMEO - CRATER".

To keep voice transmission as short and clear as possible, radio operators use procedure words (prowords) to take the place of long sentences. The prowords and meanings are listed in the following chart.

PROWORD	MEANING
ALL AFTER.....	I refer to the portion of the message that follows _____.
ALL BEFORE.....	I refer to the portion of the message that precedes _____.
BREAK.....	I hereby indicate the separation of the text from other portions of the message. Or: I have completed the text of the message, signature follows, etc. (When "break-in" is permitted, receiving operator may interrupt the transmitting operator to request a re-transmission of a portion of a message. The proword is the interruption sign).
CORRECTION.....	An error has been made in this transmission. Transmission will continue with the last word correctly transmitted.
DISREGARD THIS TRANSMISSION.....	This transmission is in error. Disregard it. (This proword will not be used to cancel any message that has been completely transmitted and for which receipt has been acknowledged.)

PROWORD	MEANING
DO NOT ANSWER.....	Stations called are not to answer this call, receipt for this message, or otherwise to transmit in connection with this transmission. When this pro-word is employed, the transmission will be ended with the proword "out".
EXECUTE.....	Carry out the purpose of the message or signal to which this applies. To be used only with the Executive Method.
EXECUTE TO FOLLOW.....	Action on the message or signal which follows is to be carried out upon receipt of the proword EXECUTE. To be used only with the Executive Method.
EXEMPT.....	The addressee designations immediately following are exempted from the collective call.
FLASH.....	Precedence FLASH
FROM.....	The originator of this message is indicated by the address designation immediately following.
IMMEDIATE.....	Precedence IMMEDIATE
INFO.....	The addressee designations immediately following are addressed for information.
I READ BACK.....	The following is my response to your instructions to read back.
I SAY AGAIN.....	I am repeating transmission (or portion) indicated. (NOTE: The term REPEAT is not used to request a read back of a portion of a transmission. The term REPEAT is primarily used in mortar, air strike and artillery activity indicating a repeat of a fire mission.)

PHONETIC ALPHABET

Ltr	Word	Pronunciation	Ltr	Word	Pronunciation
A	ALPHA	<u>AL</u> FAH	N	NOVEMBER	NO <u>VEN</u> BER
B	BRAVO	<u>BRAH</u> VO	O	OSCAR	<u>OSS</u> CAH
C	CHARLIE	<u>CHAR</u> LEE	P	PAPA	PAH PAH
D	DELTA	<u>DELL</u> TAH	Q	QUEBEC	KEH <u>BECK</u>
E	ECHO	<u>ECK</u> OH	R	ROMEO	<u>ROW</u> ME OH
F	FOXTROT	<u>FOKS</u> TROT	S	SIERRA	<u>SEE</u> AIR RAH
G	GOLF	<u>GOLF</u>	T	TANGO	<u>TANG</u> GO
H	HOTEL	<u>HOH</u> TELL	U	UNIFORM	<u>YOU</u> NEE FORM
I	INDIA	<u>IN</u> DEE AH	V	VICTOR	VIK TAH
J	JULIETT	<u>JEW</u> LEE <u>ETT</u>	W	WHISKEY	<u>WISS</u> KEY
K	KILO	<u>KEY</u> LOH	X	X-RAY	<u>ECKS</u> RAY
L	LIMA	LEE MAH	Y	YANKEE	<u>YANG</u> KEE
M	MIKE	MIKE	Z	ZULU	<u>ZOO</u> LOO
PHONETIC NUMBERS					

NUMBER	FRONUNC IAT ION	NUMBER	FRONUNC IAT ION
1	WUN	6	SIX
2	TOO	7	SEV-en
3	TREE	8	AIT
4	FOW-er	9	NIN-er
5	FIFE	∅	ZE - ro

I SPELL..... I shall spell the next word phonetically

I VERIFY..... The following message (or portion) has been verified at your request and is repeated. To be used only as a reply to VERIFY.

MESSAGE FOLLOWS..... A message which requires recording is about to follow. (transmitted immediately after the call)

NUMBER..... Station Serial Number

OUT..... This is the end of my transmission to you and no answer is required or expected.

OVER..... This is the end of my transmission to you and a response is necessary. Go ahead; transmit.

PRIORITY..... Precedence PRIORITY

READ BACK..... Repeat this entire transmission back to me exactly as received.

RELAY TO..... Transmit this message to all addresses or to the address designations immediately following.

ROGER..... I have received your last transmission satisfactorily.

ROUTINE..... Precedence ROUTINE

SAY AGAIN..... Repeat all of your last transmission. Followed by identification data means "Repeat _____ (portion indicated).

SIGNALS FOLLOW	The groups which follow are taken from Signals book. (This proword need not be used on nets primarily employed for conveying signals. It is intended for use when tactical signals are passed on non-tactical nets).
SILENCE.....	CEASE Transmissions immediately. Silence will remain until instructed to resume. (When an authentication system is enforced, transmissions imposing silence are to be authenticated).
SILENCE LIFTED.....	Resume normal transmissions. (Silence can be lifted only by the station imposing it or by higher authority. When an authentication system is in force, transmissions lifting silence are to be authenticated.)
SPEAK SLOWER.....	Your transmission is at too fast a speed. Reduce speed of transmission.
THAT IS CORRECT.....	You are correct, or what you have transmitted is correct.
THIS IS.....	The transmission is from the station whose designation immediatly follows.
TIME.....	That which immediately follows is the time or date-time group of the message.
TO.....	The addressees whose designations immediately follow are to take action on this message.

PROWORD	MEANING
UNKNOWN STATION.....	The identity of the station with whom I am attempting to establish communication is unknown.
VERIFY.....	Verify entire message (or portion indicated) with the originator and send correct version. To be used only at the discretion of or by the addressee to which the questioned message was directed.
WAIT.....	I must pause for a few seconds.
WAIT OUT.....	I must pause for longer than a few seconds.
WILCO.....	I have received your message, understand it, and will comply. (to be used only by the addressee. Since the meaning of ROGER is included in that of WILCO, the two prowords are never used together.
WORD AFTER.....	I refer to the word that follows _____.
WORD BEFORE.....	I refer to the word that precedes _____.
WORDS TWICE.....	Communication is difficult. Transmit (ing) each phrase or each code group twice. This proword may be used as an order, request, or as information.
WRONG.....	Your last transmission was incorrect. The correct version is _____.

PATROLLING

1. INTRODUCTION

During the tactics phase of your individual training, you will participate in the most arduous and challenging single activity in your training schedule: Patrolling. Most of the training hours that you have thus far received have been in preparation for the individual challenges you will receive during the training in techniques of patrolling.

2. SCOPE

This portion of your handbook will discuss the general aspects of patrolling, including the pertinent tactical diagrams and hand-outs that will be used during the academic classroom portion of the training. The classroom portion of patrolling is by necessity both brief and cursory. Classroom instruction, map exercises, films and diagrams are valuable aids in learning the basic concepts and techniques of patrolling. THEY ARE NOT SUBSTITUTES FOR ACTUAL PERFORMANCE IN THE FIELD. Field exercises of an arduous and realistic nature will constitute the bulk of the training in this important phase.

The techniques discussed are those generally applicable to all situations, however these techniques are meant as guides to the student, and not an iron clad rule to follow. The student is expected to develop his own methods and techniques as the training progresses and he will be graded on the degree of their success.

3. WHAT IS A PATROL

A patrol is a detachment sent out from a unit to perform an assigned mission of reconnaissance or combat, or a combination of both.

a. The requirements of the mission determine the size, organization and equipment of the patrol. Some missions may require only two or three men, lightly armed, and with no extensive equipment requirements. Some missions may require patrols of fire team or combined fire team size, specially armed and equipped, with extensive coordination required with other sections and units for fire support, air support, etc.

b. A patrol is always tailored for the mission it is to perform.

4. IMPORTANCE OF PATROLS

a. Patrols are limited only by the ingenuity with which they are employed and the skill and aggressiveness of their members. For this reason, they are the Commander's most valuable tools.

b. Patrols are especially valuable in counter-guerilla operations. Aggressive patrolling in an area greatly reduces the guerilla's freedom of movement, hampers their operations, and weakens their influence on the local population.

5. PATROL PROFICIENCY

Patrolling by the Combat Security forces of the USAF is limited for the most part to relatively short range combat and reconnaissance patrols designed to clear and secure a specific area and to interdict the enemy movement of supplies and personnel to and through the secured area. This concept of "active defense",

with offensive overtones, is a concept peculiar to the USAF Combat Security forces and resulted in a marked degree of success with a test area in the Republic of Vietnam in the Spring of 1967. The training requirement for these relatively "short range" patrols is the same training received by infantry long range patrol units, as the techniques of patrolling are the same in both cases. Logically, a unit well trained in short range patrolling would be capable of mounting a long range patrol action with very little adjustment in mission requirements.

b. Proficiency in patrolling requires proficiency in many areas. Patrol training is unique in affording the opportunity to enhance proficiency in many vital allied skills. Skills that are integrated into patrolling exercises include:

- (1) Leadership
- (2) Combat Intelligence
- (3) Map Reading
- (4) Land Navigation
- (5) Small Unit Tactics
- (6) Communications
- (7) Ability to Operate at Night
- (8) Camouflage and Concealment
- (9) Physical Endurance

101

6. TYPES OF PATROLS

a. Patrols are classified according to the nature of the mission assigned.

(1) RECON PATROLS collect information and confirm or disprove the accuracy of information previously received. Recon Patrols are further classified as:

- (a) Point Reconnaissance Patrols.
- (b) Area Reconnaissance Patrols

(2) COMBAT PATROLS provide security and harass, destroy, or capture enemy personnel and equipment. Combat patrols also collect and report information, whether related to the assigned mission or not. Combat patrols are further classified as:

- (a) Raid/Search and Clear
- (b) Ambush Patrols
- (c) Security Patrols

7. EXPLANATION OF PATROLLING TERMS

As you progress through the academic portion of your patrolling training, you will be exposed to a terminology that will, for the most part, be new to you and different from terminology normally found in USAF ground units. To assist you in understanding the meaning of these terms, the following explanations are provided:

a. Fire Team Operations: A patrol activity consisting of a fire team composed of 6 men. The organization of this type of patrol is simplified by the fact that each member of the patrol performs his usual assignment within the structure of the fire team.

b. Combined Fire Team Operations: A tactical activity consisting of two or more fire teams in a patrol action. This type of patrol requires organization into elements with specific individual and team assignments. Combined Fire Teams may be used as large ambush forces, blocking forces and raid/search and clear patrols.

c. General Organization: The establishment of major subdivisions within the patrol called elements.

d. Elements: Major sub-divisions of a patrol. Establishments of elements is the first step in organizing a patrol. The elements into which a patrol is organized is determined by the mission of the patrol.

(1) Assault Element: (Combat Patrols). Engages the enemy at the objective.

(2) Security Element (Recon and Combat patrols). Provides early warning and protection in objective area, and to and from the objective.

(3) Support Element: (Combat Patrols). Provides supporting fires at the objective.

(4) Reconnaissance Element: (Recon Patrols). Reconnoiters or maintains surveillance over the objective.

- d. Special Organization: The organization of elements into teams.
- e. Individual Organization: The assignment of specific tasks to individuals within a patrol, i.e., point, compass man, etc.
- f. Teams: Subdivision of elements. (Assault, security, recon, etc.)
- g. Rallying Point: (RP). A place where the patrol can assemble and reorganize. An RP must be free of the enemy, provide concealment, be defensible for at least a short period of time, and be easily recognizable by all members of the patrol. There are three types of Rallying Points:
- (1) Initial Rallying Point: (IRP) A point within friendly areas where the patrol can rally if it is dispersed before departing friendly areas.
 - (2) Rallying Points Enroute: (RPE) Rallying Points between friendly areas and the objective. May be designated by map recon or while patrol is enroute.
 - (3) Objective Rallying Point: (ORP) A Rallying Point near the objective. Used as a point from which the leaders recon is made, where patrol can make final preparations, and re-group later for return to friendly lines.
- h. Team Release Point: (TRP) Usually a point beyond the ORP where the patrol leader releases teams to go forward to the objective. The ORP may also be the TRP.

- i. Leaders Recon: Recon by patrol leader, (and subordinate leaders when situation permits) to confirm location of the objective, plan for the positioning of teams, and plan for the accomplishment of the mission. Reconning personnel move no closer to the objective than is necessary to accomplish this task. Leaders recon is normally conducted from the ORP.
- j. Chance Contact: Unplanned visual or physical contact with the enemy while on patrol.
- k. Immediate Action Drills: Drills designed to provide swift and positive small unit reaction to enemy contact.
- l. Ambush: A surprise attack from a concealed position on a temporarily halted or moving target.
- m. Raid: A surprise attack on a position or installation with the attacking force withdrawing after accomplishing its mission.
- n. Warning Order: A preliminary notice of an order or action that is to follow. It is designed to give patrol members time and information needed to prepare for patrol. Given verbally, it is also a sequence of events.
- o. Patrol Order: The orders issued by the patrol leader setting forth the situation, mission details of execution, special equipment and communications required for an impending patrol action.

105

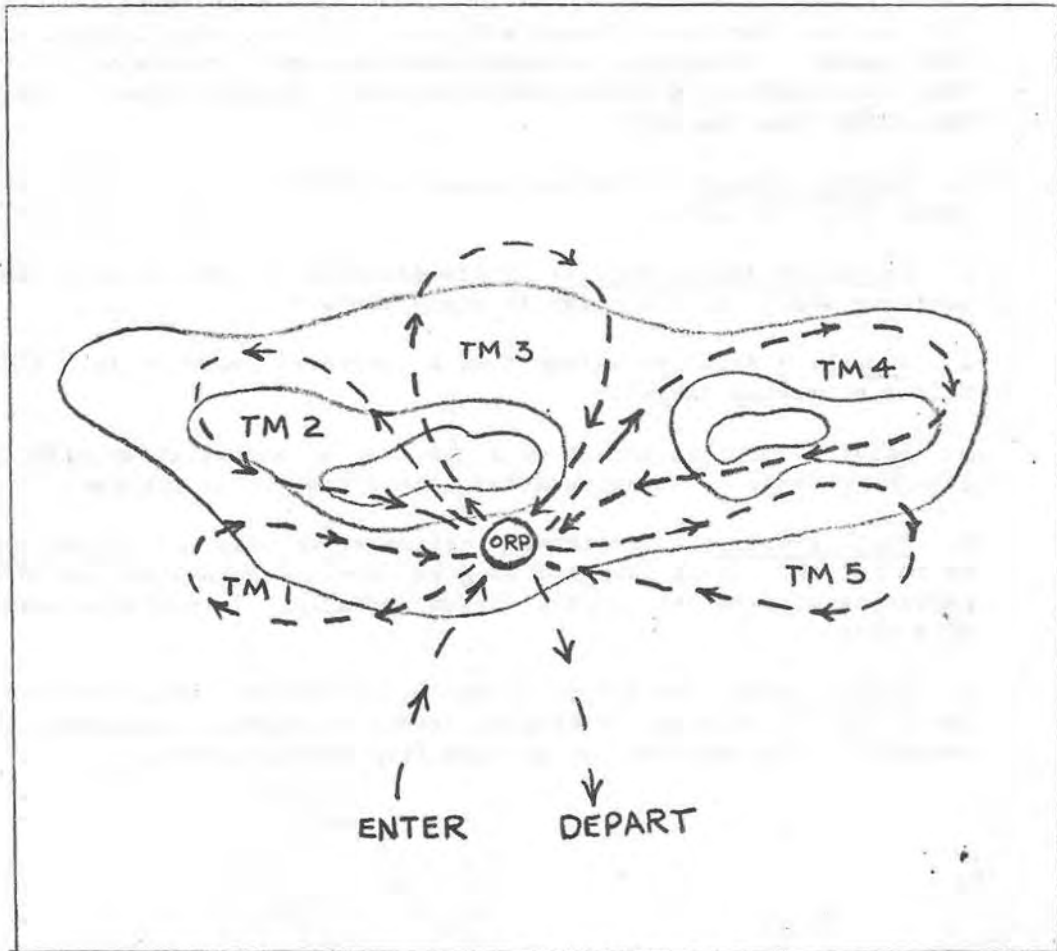

FIGURE 42. FAN METHOD OF AREA RECONNAISSANCE

106

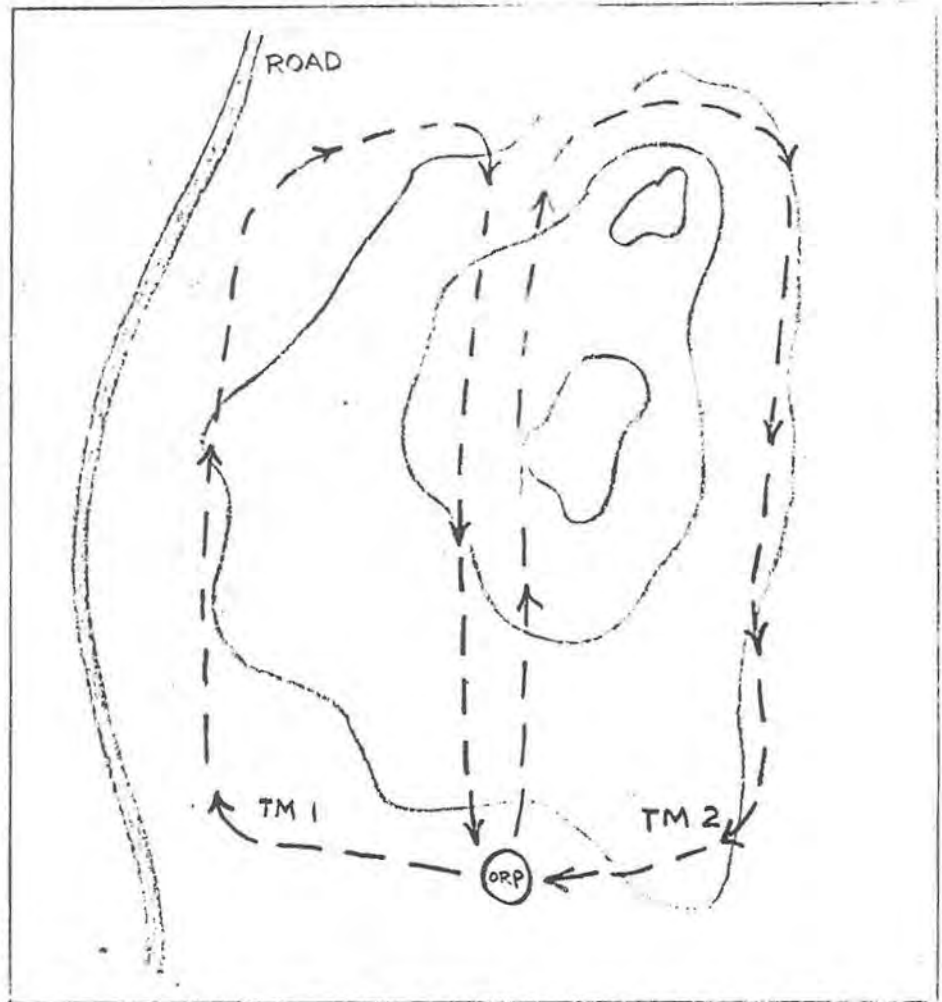

FIGURE 43. BOX METHOD OF AREA RECONNAISSANCE 107

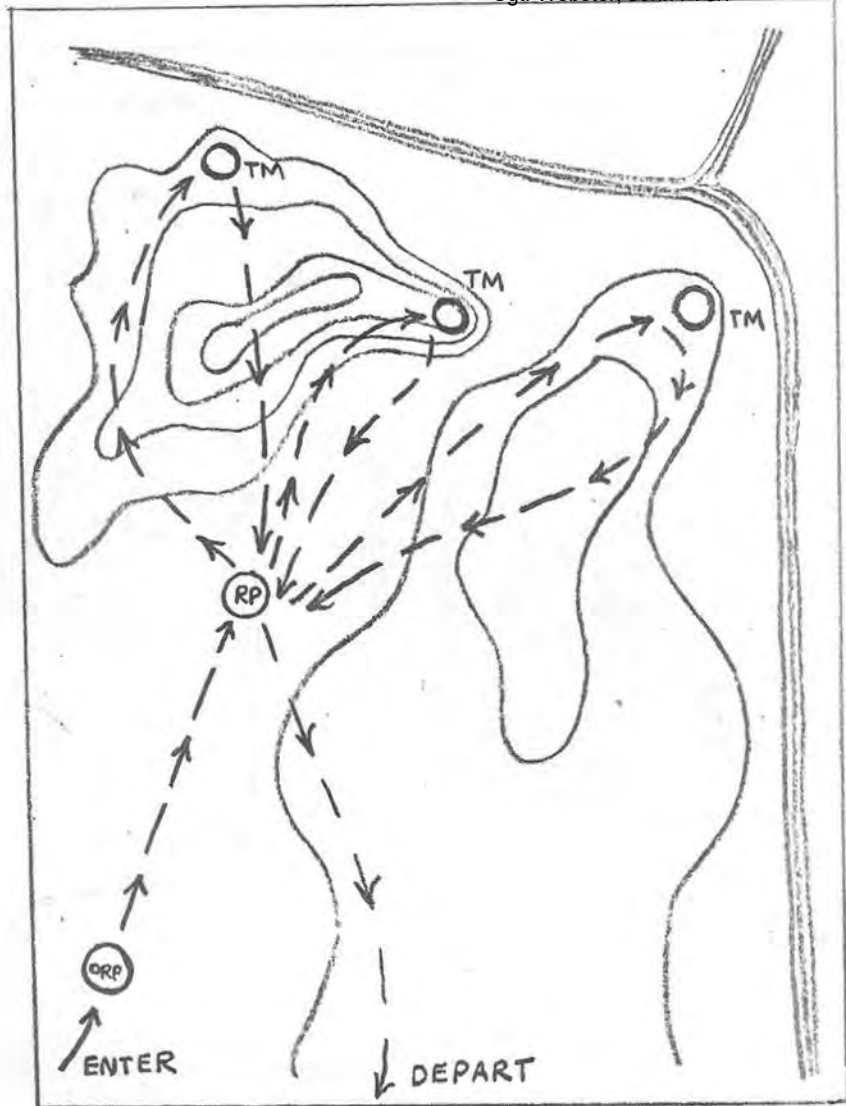
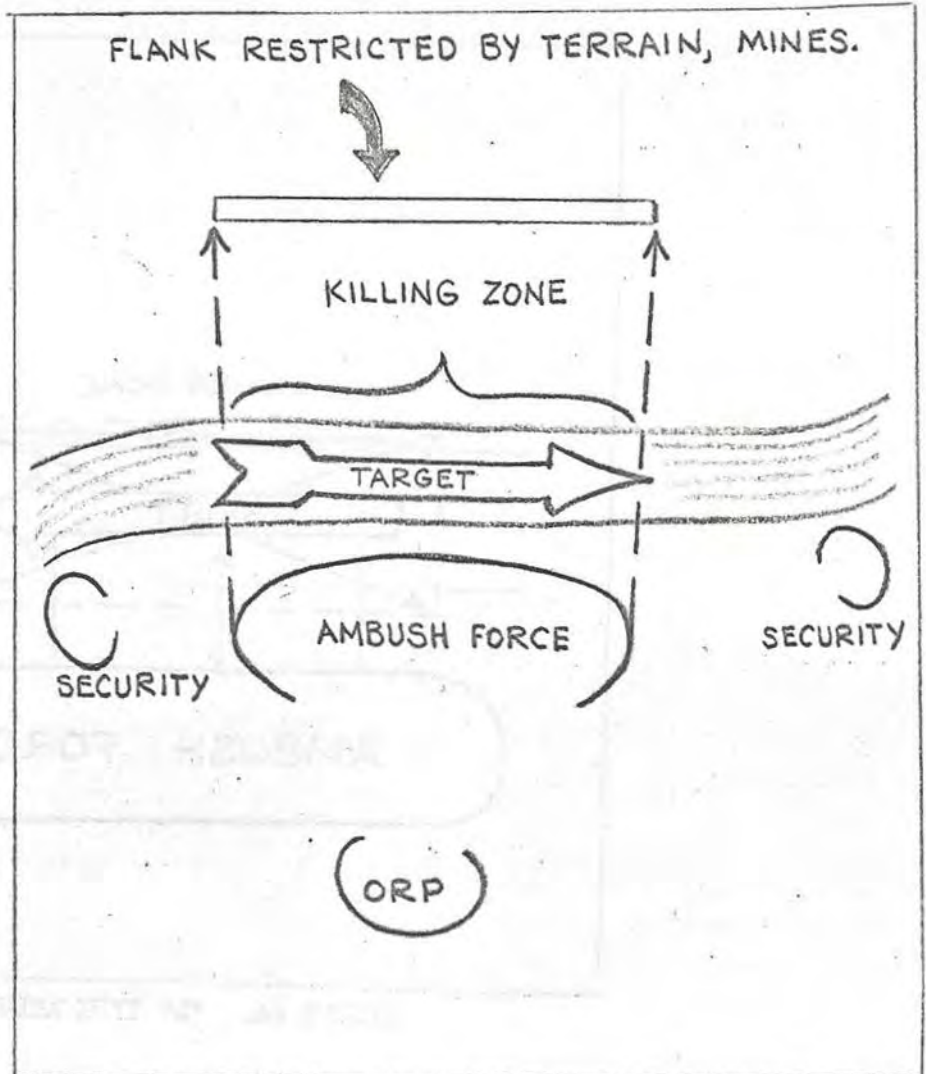

FIGURE 44. AREA SURVILLANCE

108



109

FIGURE 45. LINEAR AMBUSH

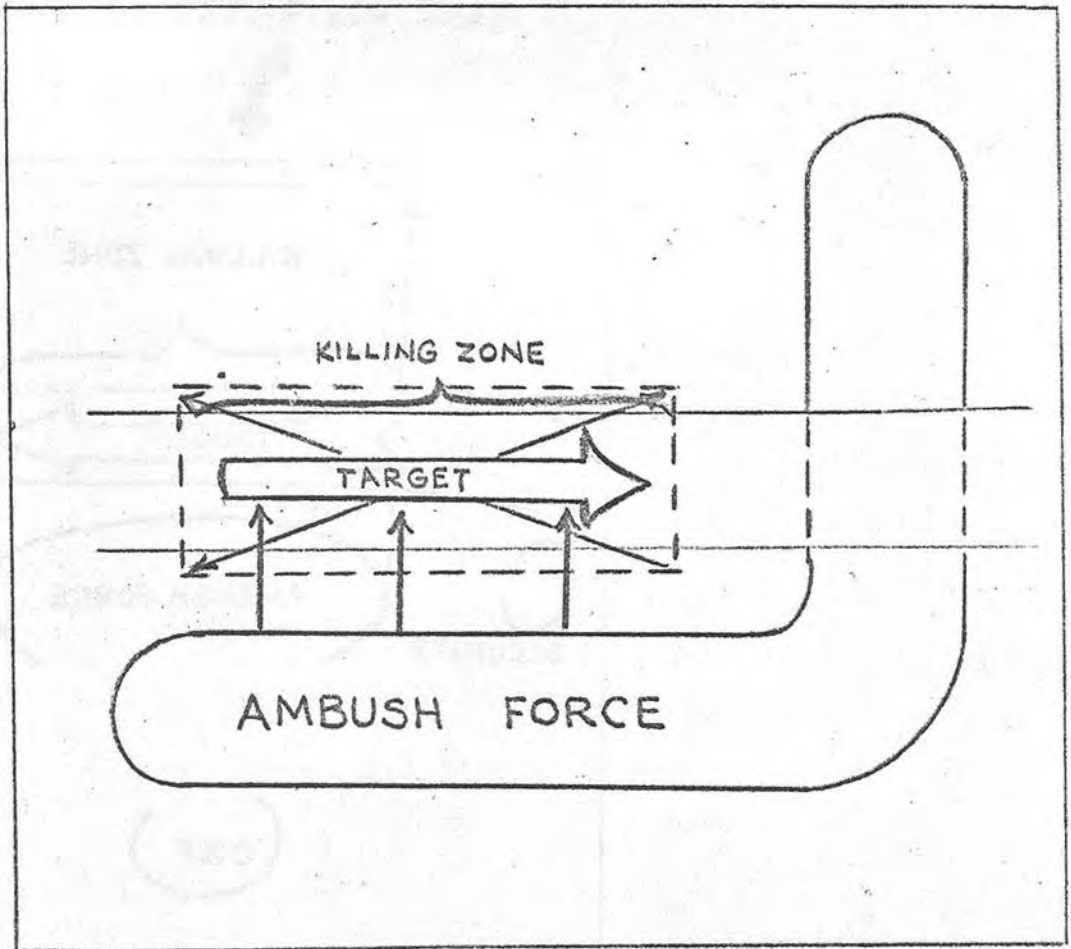

FIGURE 46. "L" TYPE AMBUSH

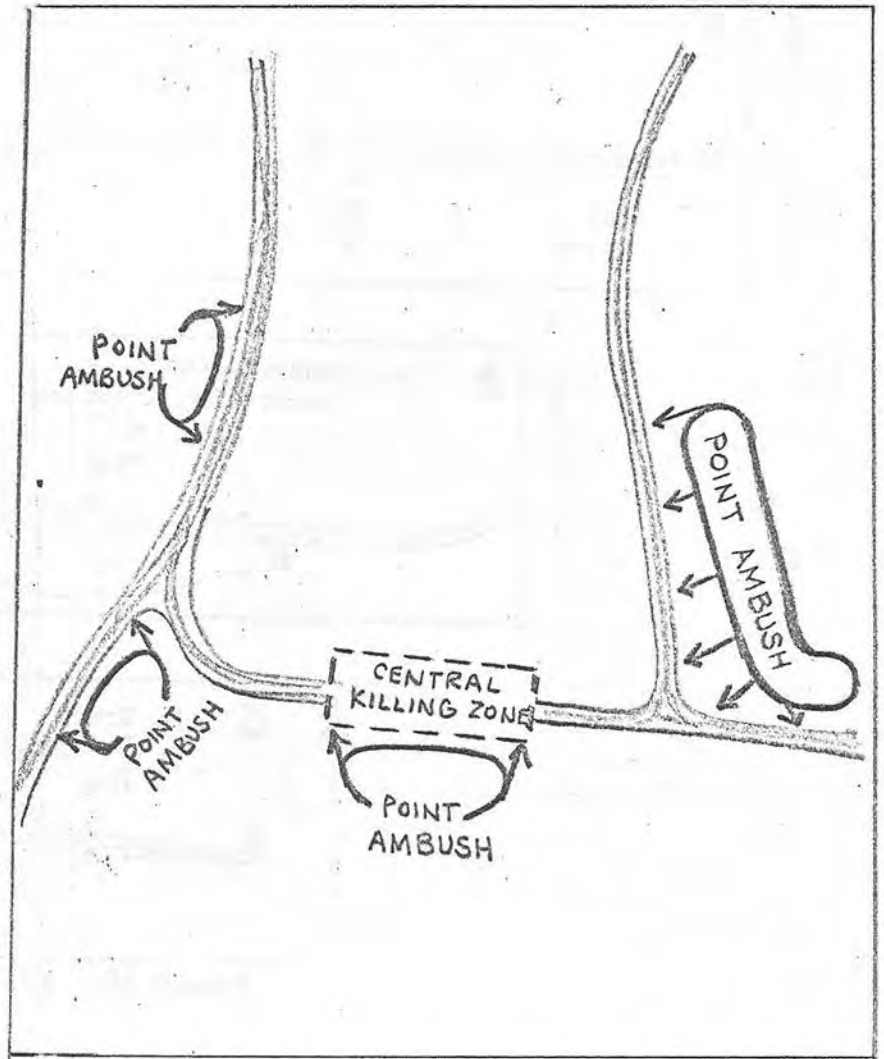

FIGURE 47. AREA AMBUSH (BRITISH VERSION)

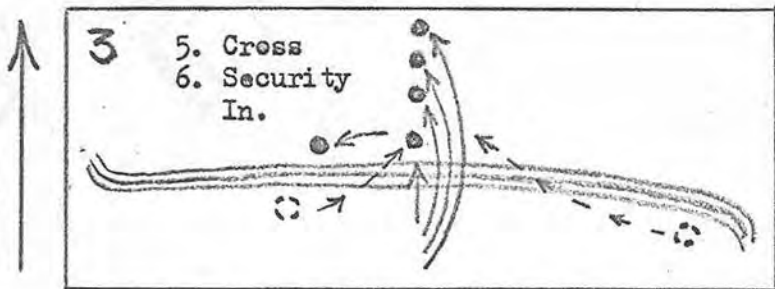
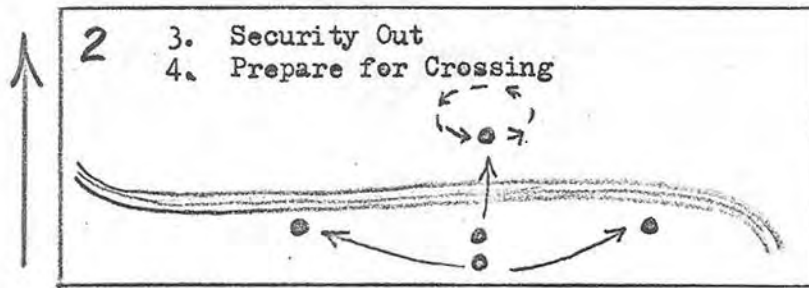
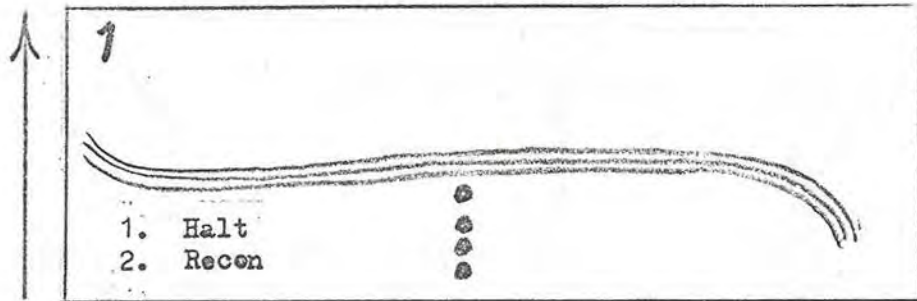
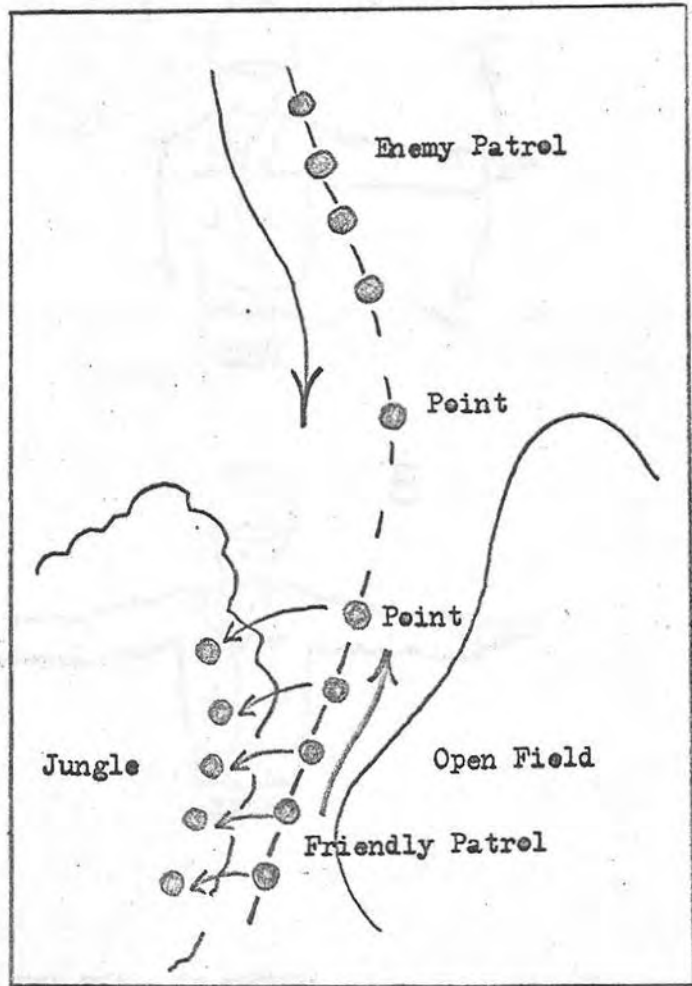

FIGURE 48. ACTIONS AT DANGER AREAS



113

FIGURE 49. HASTY AMBUSH

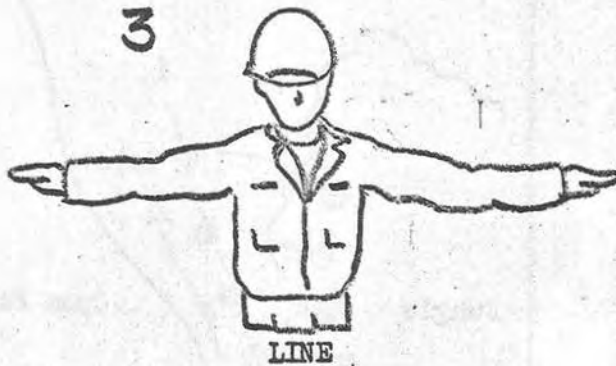

FIGURE 50. ARM AND HAND SIGNALS



ASSEMBLE

5



(POINT TO ASSEMBLY AREA)

6



COLUMN

7



(Both Hands)

MODIFIED COLUMN

FIGURE 51. ARM AND HAND SIGNALS

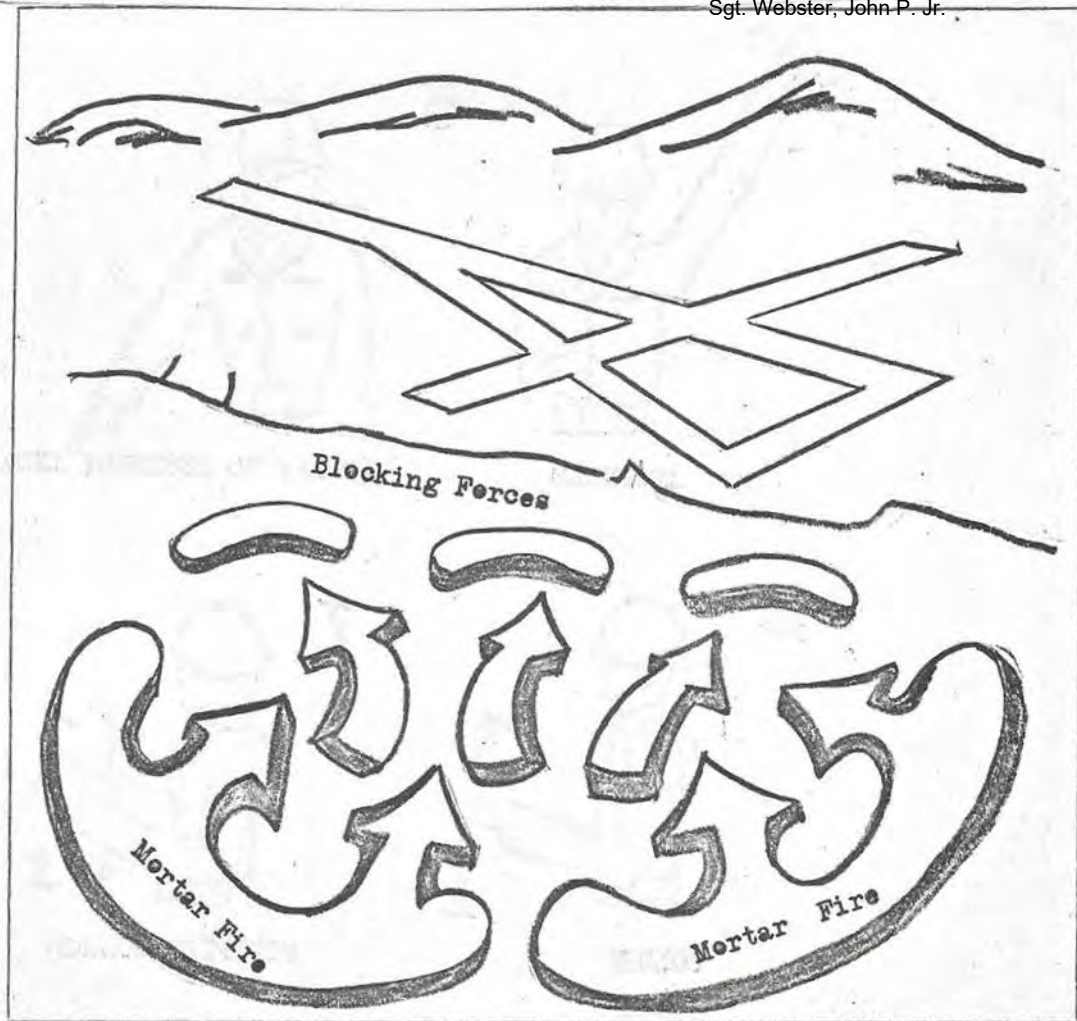

FIGURE 52. USE OF BLOCKING FORCES IN AIR BASE DEFENSE

FIELD SANITATION AND HYGIENE

There is a popular belief that sanitation and personal hygiene are areas of personal activity that apply basically to troops in garrison, and that when a unit is operating in the field, these important functions are of secondary importance at best. Nothing could be further from the truth. When troops are living in the field, removed from modern bathing and waste disposal facilities, it becomes doubly important that the details of hygiene and sanitation are properly attended to, in order to avoid the spread of filth, disease and pestilence that can reduce an army in the field to ineffectiveness.

1. PERSONAL HYGIENE IN THE FIELD

Operating in the field, whether in training or in combat, the soldier must insure that he keeps himself physically fit to perform his duty. It is understood that the minimum standards will keep the soldier fit to perform his function if they are followed closely.

a. Bathing: Under field conditions that you will be participating in during your training phase, it will be virtually impossible to take a complete bath, however, even the limited bathing possibilities available to you will make the difference between possible poor health and disease or keeping fit in the field. Daily washing of the armpits, ears, feet and crotch with soap and water is the most important part of field hygiene. Troops should be clean shaven and the teeth should also be brushed as often as possible to avoid problems with oral hygiene. If possible the hair should be washed at least once weekly with soap and water.

117

b. Clothing: Clothing easily becomes contaminated with disease agents resulting from contact with agents present in stool, urine and surface garbage. Underclothing, if possible, should be changed daily. Outer clothing should be washed when it has become excessively dirty, if possible. Shaking of clothing, followed by two (2) hours of airing or sunning, will greatly reduce the content of disease germs. The shaking should always be done out of doors and not in tents.

c. Care of the Feet: The mission of this unit depends a great deal upon the physical fitness of its members. This is especially true when applied to the condition of the feet of the individual member, because in this business, your feet are as much the tools of your trade as your rifle and combat field equipment. Serious foot trouble can usually be prevented by observance of the following simple rules of foot hygiene.

(1) The Proper Fitting of Shoes: Expert fitting at the time of purchase or issue of combat boots is absolutely essential. There should be no binding or pressure spots; neither should the boots be so large that it will permit the foot to slide forward and backward when walking. Do not participate in arduous field activities with newly issued or purchased boots and expect to return from the field with your feet in condition to continue the training phase.

(2) Socks: Socks should be changed daily, or washed daily to provide clean socks for the following training day. They should be large enough to allow the toes to move freely, but not so loose as to wrinkle. To allow for shrinkage, woolen socks should be at least one size larger than cotton socks. Socks with holes or poorly darned socks will cause blisters. Socks and boots should be dusted daily with the issue foot powder.

(3) Foot Marches: The foot march is the most severe test for foot fitness. Unless special attention is given to the feet of marching troops, serious casualties from foot marches can result. In preparing for a road march, be sure that your boots are in serviceable condition, your boots and socks well dusted with foot powder, and that you have extra socks for the march. If feet get wet or damp during the march, dry socks should be put on as soon as possible. Once or twice during the march the feet and boots should be dusted with foot powder. During rest periods on the march, check your feet for blisters.

(4) Washing the Feet: To avoid athlete's foot, feet should be washed daily and dried thoroughly, especially between the toes and other areas. Persons whose feet perspire freely should pay particular attention to the daily or twice daily use of foot powder.

2. FIELD SANITATION: Operating in the field, necessary facilities and devices must be improvised to protect the health of the troops. Given as general guides, the following techniques can be useful in the field.

A. Handwashing Device: Handwashing devices should be provided outside latrine enclosures and at or near field kitchen facilities. Two cans should be provided and checked frequently to see if refilling is needed.

B. Waste Disposal: Human waste consists primarily of urine and feces. This filth, if not properly disposed of in a camp site, can enter the body through various means and result in disease or intestinal parasites. Various field latrines can be constructed to dispose of this type of waste, and the two most commonly used methods will be discussed and described as follows:

119

(1) Saddle Trench Latrines: A saddle trench latrine is dug one foot wide, $2\frac{1}{2}$ feet deep, and 4 feet long. This will accommodate two men at the same time. The trenches should be at least two feet apart. There are no seats in this type of latrine, but boards may be placed along each side of the trench to provide better footing. Toilet paper should be placed on suitable holders and protected from the weather by a tin can or other cover. The earth removed in digging is piled at the end of each trench and an entrenching tool or paddle is provided for each person to cover the excrement each time the trench is used.

(2) Field Urinals: When in the field, separate devices for the disposal of urine will probably be necessary. The best device for urine disposal in the field is the urine soakage pit. This is dug 4 feet square and 4 feet deep. It is then filled with rocks, flattened tin cans, broken bottles or other coarse contact material. Pipe urinals should be at least one inch in diameter. These pipes should extend at least 8 inches below the surface of the pit. Funnels maybe constructed from tar paper or cardboard and should be filled with straw to keep out flies. All field latrines will be completely buried or covered when the unit departs the area and marked with a small sign to indicate that a latrine has been located on that spot.

D. Garbage: Cans, food leftovers, and other garbage should be buried in a deep garbage pit and well covered with several inches of soil

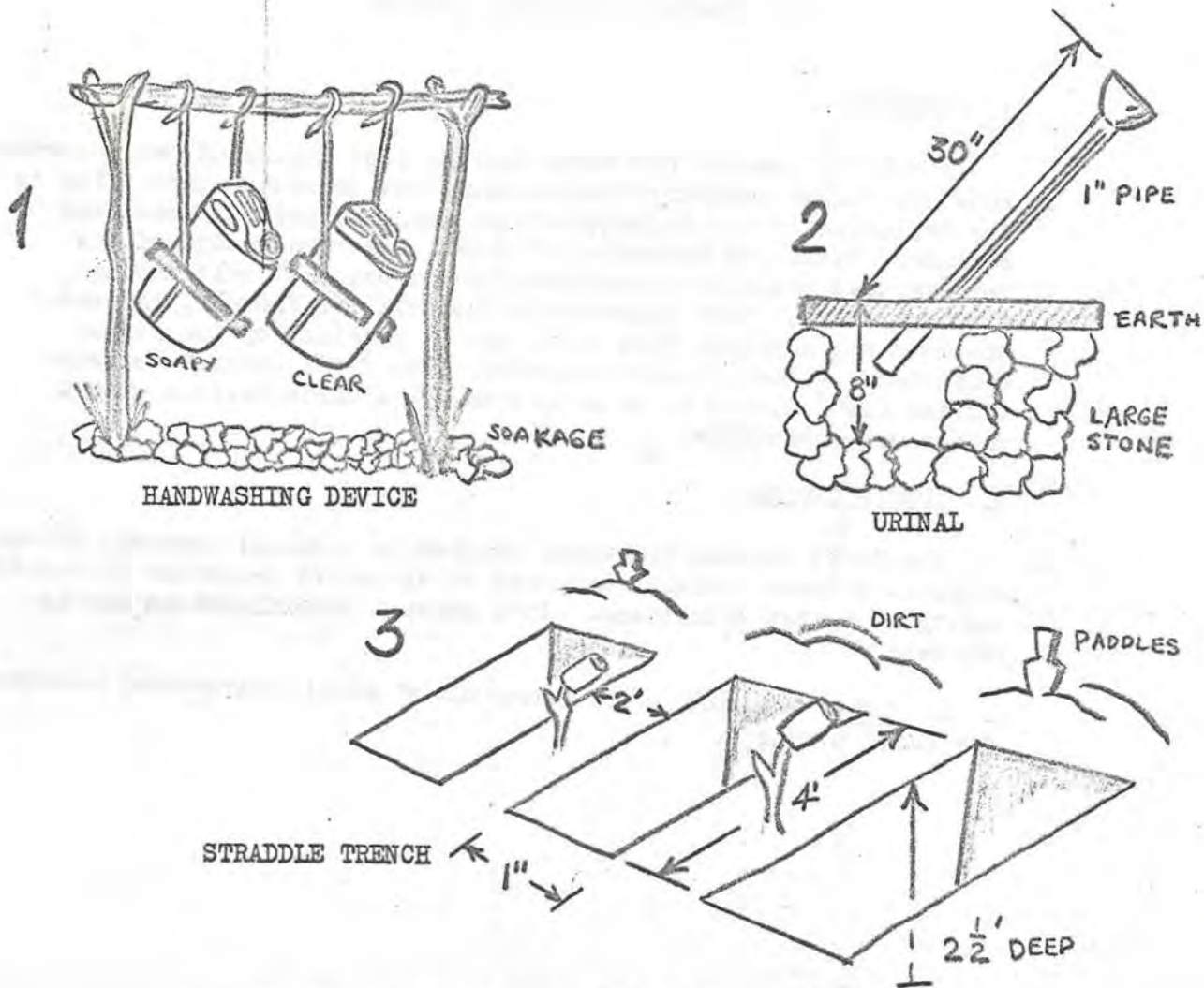

FIGURE 53. EXPEDIENT FIELD LATRINES

M-113 ARMORED PERSONNEL CARRIER

1. HISTORY

The M-113 Armored Personnel Carrier (See Figure 54) was accepted into the Combat Security Program equipment inventory just prior to the beginning of the training of the original unit at Schofield Barracks, Hawaii in September of 1966. Prior knowledge of the terrain that would be encountered by the original unit during its operational test phase in the Republic of Vietnam, indicated the need for mobility that could not be provided by the normal complement of USAF wheeled vehicles. The M-113 Armored Personnel Carrier (APC) proved to be an extremely valuable vehicle with a varied use capability.

2. SPECIFICATIONS

The M-113 Armored Personnel Carrier is a diesel powered, armored, amphibious track vehicle, designed to transport personnel in relative safety in combat situations. Its general specifications are as follows:

A. Body: The body is constructed of steel impregnated aluminum for added strength.

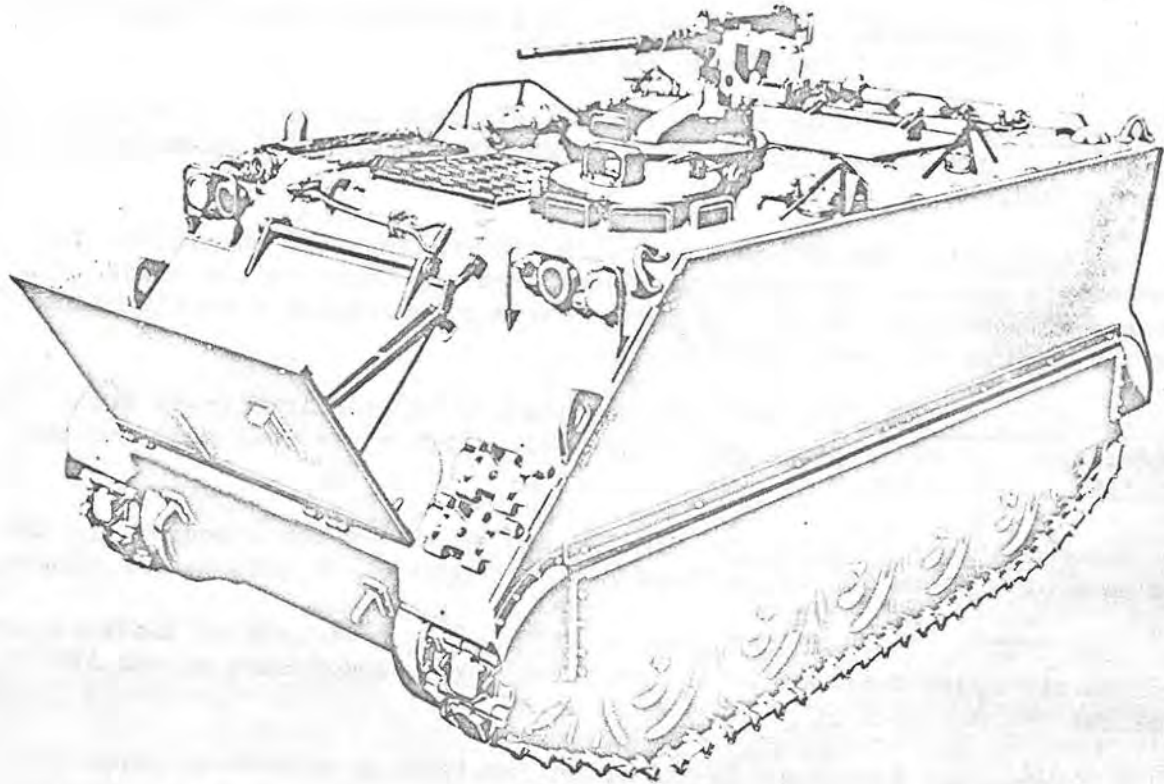

FIGURE 54. M-113 US ARMORED PERSONNEL CARRIER

123

B. Engine: The APC is powered by one GM Diesel engine.

C. Entry and Exit: There are five (5) hatches or doors, three (3) on the top of the vehicle and two in the rear.

D. Speed: Two tracks propel the vehicle at a top speed of 40 MPH. The vehicle will cruise at a speed of 20 to 25 MPH for over 200 miles on 95 gallons of fuel.

E. Armament: The APC is armed with a 50 caliber HMG mounted on the commander's cupola. More weapons can be used depending on the need. With minor modifications, the APC is also capable of providing a mobile mount for the 81MM or 4.2 heavy mortar.

F. Performance: The APC will negotiate a 60% vertical grade and a 30% slideslope. It will span a gap of $5\frac{1}{2}$ feet, climb a vertical wall and turn w within its own length.

G. Amphibious Capability: The APC can swim at a top speed of 3.5 MPH and each of the two (2) bilge pumps has an output of 44 gallons per minute.

3. EMPLOYMENT: The M-113 APC can be utilized in a variety of tactical conditions and operations due to its adaptability. Common uses of the APC include:

A. Personnel Carrier: In its basic function as an armored personnel carrier, the APC can carry 10 combat equipped personnel sitting inside in seats provided, in addition to its normal crew complement of three (3).

Additional personnel can be carried on top of the APC if armored protection for personnel is not a transport consideration.

B. Litter Carrier: The APC can be equipped with 4 litters for the evacuation of wounded personnel.

C. Cargo Carrier: The APC can be used to transport small cargo to areas where the terrain forbids the use of conventional vehicles.

D. Reconnaissance: The APC is valuable as a reconnaissance vehicle in rough terrain when time may not permit the recon of an area by foot patrols.

E. Command Post: The relatively sophisticated radio equipment in the APC lends itself nicely to the use of the APC as a mobile Command Post. In this capacity, the APC can also be used as an Alternate Command Post in the event the primary command post is neutralized by equipment failure or enemy action.

F. Radio Relay: The APC is an effective radio relay station. By positioning itself on high ground within your operating area, units in the field with a weak radio power source can relay messages through the APC to the Unit Command Post.

G. Limited Assault Vehicle: As a mobile mount for the 50 Cal Heavy Machine Gun, the APC can be deployed in support of troops assaulting a position, but its use as an offensive assault vehicle is limited to troop support only.

H. Rescue and Recovery: With its normal personnel complement of a fire

125

team and crew, the APC has a valuable use in rescue and recovery missions in support of personnel who have engaged a numerically superior enemy force or who are pinned down by enemy ground fire.

MAP READING INFORMATION

1. INTRODUCTION

A map is a graphic representation of the earth's surface or part of it, drawn to scale on a plane. Manmade and natural features are depicted by symbols, lines and colors.

A map is as important to the ground defense specialist as his weapon or any other piece of field equipment, particularly when operating in terrain totally unfamiliar to him. When used correctly a map can give accurate distances, locations, heights, best routes, key terrain features and cover and concealment information.

2. CARE OF MAPS

The map is so important, and in many cases so easily lost, damaged or destroyed that great care must be exercised to preserve it. Maps are keyed to certain areas, thus requiring many sheets; therefore, every caution must be taken to effect economy to reduce the logistic effort required to maintain an adequate supply where needed.

One of the first considerations in the care of maps is the proper folding of the map itself. Figure 55 shows two ways of folding a map so as to make it small enough to be carried easily and still be available for use without having to unfold the whole map. This is called the "accordien fold". Another method of folding a map or chart into a smaller size is illustrated in Figure 56. This method is accomplished by cutting a slit in the map as illustrated. The map can then be folded by following the instructions in numerical order.

After folding a map correctly, the next problem is to protect it. Most maps are printed on paper and require protection from water, mud, tearing, etc. Whenever possible, carry a map in a waterproof packet, a pocket, under an outer garment or some place where it is handy for use, but protected. Care must also be exercised when using the map

as it may have to last for a considerable period of time. When it becomes necessary to make marks upon the map, use light lines so that they may be erased easily without smearing or smudging, or leaving marks that may later cause confusion.

3. SECURITY OF MAPS

A map, although not usually a security document, may at times require special handling and protection. Should a map fall into enemy hands, it may give an indication of future plans or areas of interest. Even more important would be a map upon which the movements of troops or positions may have been marked. For this reason, patrol leaders should never mark friendly positions on maps he intends to use in the field, although enemy positions may be marked. Destruction of unusable or unneeded maps is best done by burning, making sure that all of the map is burned and then scattering the ashes. Should burning not be possible, tear it into small pieces and either bury them or scatter them over as large an area as possible.

4. TYPES OF MAPS

For our own purposes, there are primarily three types of maps that will be of specific interest to you. They are:

(a) Topographical Maps: A two dimensional map which shows relief and distance in some form.

(b) Photomosaic: An assembly of aerial photographs to form a composite picture.

(c) Photomap: A reproduction of a photograph or photomosaic upon which grid lines, marginal data, place names and boundaries may be added.

4. MARGINAL INFORMATION

Before placing into use any piece of equipment, an intelligent operator always reads the manufacturers book of instruction. This is also true with maps but the instructions are placed around the outer edge of the map and are known as marginal information. All maps are not the same, so it becomes necessary, every time a different map is used, to carefully examine the marginal information. Marginal information of particular interest to members of the Combat Security units include:

- a. Sheet Name: Normally, the prominent cultural or geographic feature.
- b. Sheet Number: A reference number assigned to each map sheet.
- c. Scale: One unit of measure on map equal to designated number of the same unit of measure on the ground. (i.e., one inch on map equal to 25,000 inches on ground).
- d. Scale Note and Bar Scale:
 - (1) Scale Note: Same as c. above.
 - (2) Bar Scale: Miles, meters and yards.
- e. Credit Note: Who originated map and dates. Dates will tell map user how current map is.
- f. Index to Adjoining Sheets: Identifies map sheets surrounding present map.

129

- g. Index to boundary diagram: Shows boundaries and principal shorelines within map area.
- h. Grid Note: The distance between black grid lines.
- i. Grid Reference Box: Identifies grid zone and 100,000 meter square in which the area represented by the map is located and instructions for giving grid references.
- j. Legend: Illustrates and identifies some of the symbols used on the map.
- k. Declination Diagram: Indicates the relationship of map features to true north, grid north, and magnetic north.
- l. Protractor Scale: Used for laying out a magnetic north line on the map. Instructions below declination diagram.
- m. Contour Interval: Gives the vertical distance between countour lines.

5. SYMBOLS

Symbols are used to represent natural and man-made features on the earths surface, and are found on topographical maps. The symbols that re used resemble, as much as possible, the actual features themselves, as viewed from above.

130

- a. Buildings
- b. Water Towers
- c. Cemetery
- d. Bridge
- e. Roads
- f. Railroads

For clarity, some of the features must be exaggerated, when actual size of the object may be too small to see with the naked eye on the map. Not all symbols are the same; for this reason the legend is provided on the topographical map. Always refer to the legend when using a map.

6. COLORS

For easier identification of features, colors are used to provide a more natural appearance and contrast. Each color represents a type of feature:

- a. Black - majority of cultural or man-made features.
- b. Blue - Water
- c. Green - Vegetation
- d. Brown - All relief features, such as contours, cuts, and fills.

e. Red - Main roads and special features.

f. Other Colors - may be used and should be portrayed in the legend.

7. GRIDS

If you wish to meet someone within the city, it easy to effect that rendezvous by suggesting a meeting place at a specific landmark within the city that is familiar to both of you. However, how would you relay the same request to a person you wish to meet deep in an unfamiliar forest where no familiar landmarks exist to effect a tactical military link-up? The military must use a more sophisticated and sure method of giving locations, and this method will have the following characteristics:

- a. Does not require a knowledge of the area.
- b. Applies to large areas.
- c. Does not require land marks.
- d. Applies to all map scales.

To satisfy the requirements of these four characteristics, the military uses the Universal Transverse Mercator Grid (UTM), a grid system consisting of two sets of parallel straight lines, intersecting at right angles, forming a series of squares. (Figure 57). Each line of the grid system has a number, and these numbers are used to identify individual squares.

a. The first half of the coordinates (numbers) given always refer to the North/South grid line.

b. The second half of the coordinates always refers to the East/West grid line. EXAMPLE: 8993 indicates this complete grid square. This is not normally sufficient for military use.

8. LOCATING POSITIONS

a. To identify locations to within ten or one hundred meters, each square is subdivided into tenths or hundredths.

b. Meters are used primarily in military measurement.

c. Normally, for Army or our use, to within 10 meters of a position is required.

d. The designation of a point always follows the rule: "READ RIGHT AND UP".

9. MAP READING INSTRUCTION

You will receive many hours of instruction in Map Reading, and it will become obvious to you that the Combat Security School places a great deal of emphasis on Map Reading. When you begin to patrol and plan missions with your maps, you will realize why such emphasis on Map Reading is necessary. It would be impossible to provide you with enough information in this handbook to teach you how to read a topographic map. The US Army has devoted entire manuals to this task, as has the training cadre devoted many of hours of instruction to teach

you this important function. There is no short-cut in learning the techniques of map reading. Pay close attention to what you are exposed to in the classroom and in the field. Its importance cannot be too strongly stressed.

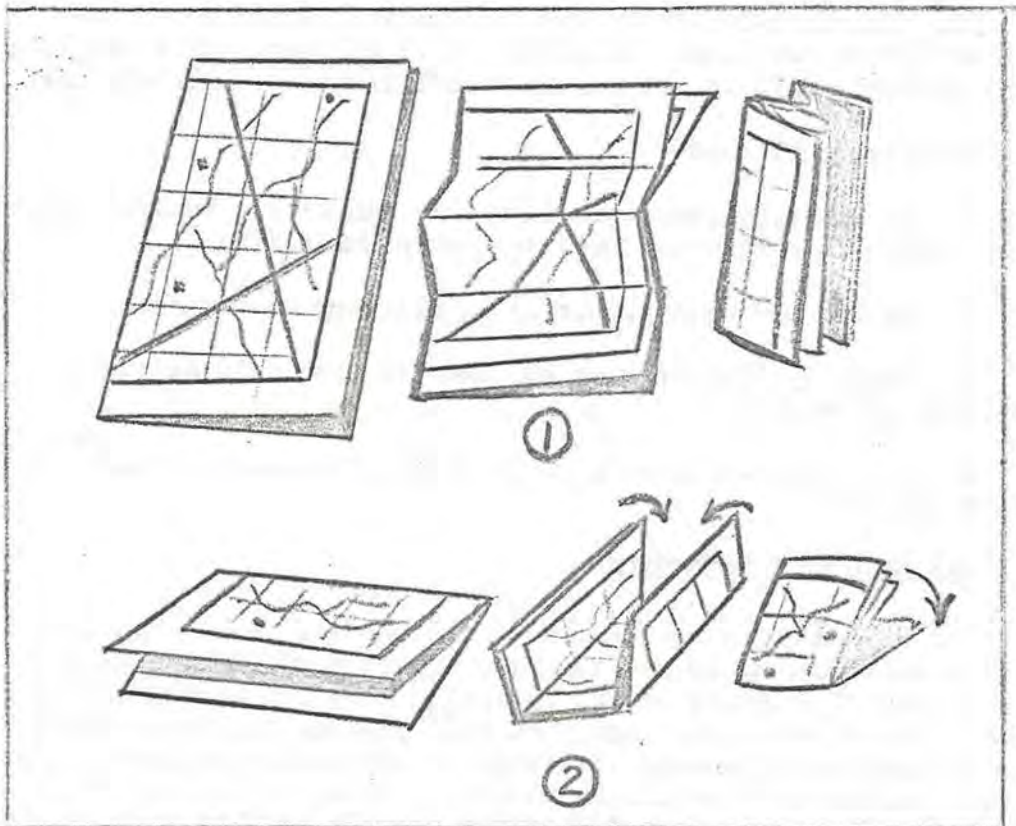

FIGURE 55. TWO METHODS OF THE ACCORDION FOLD

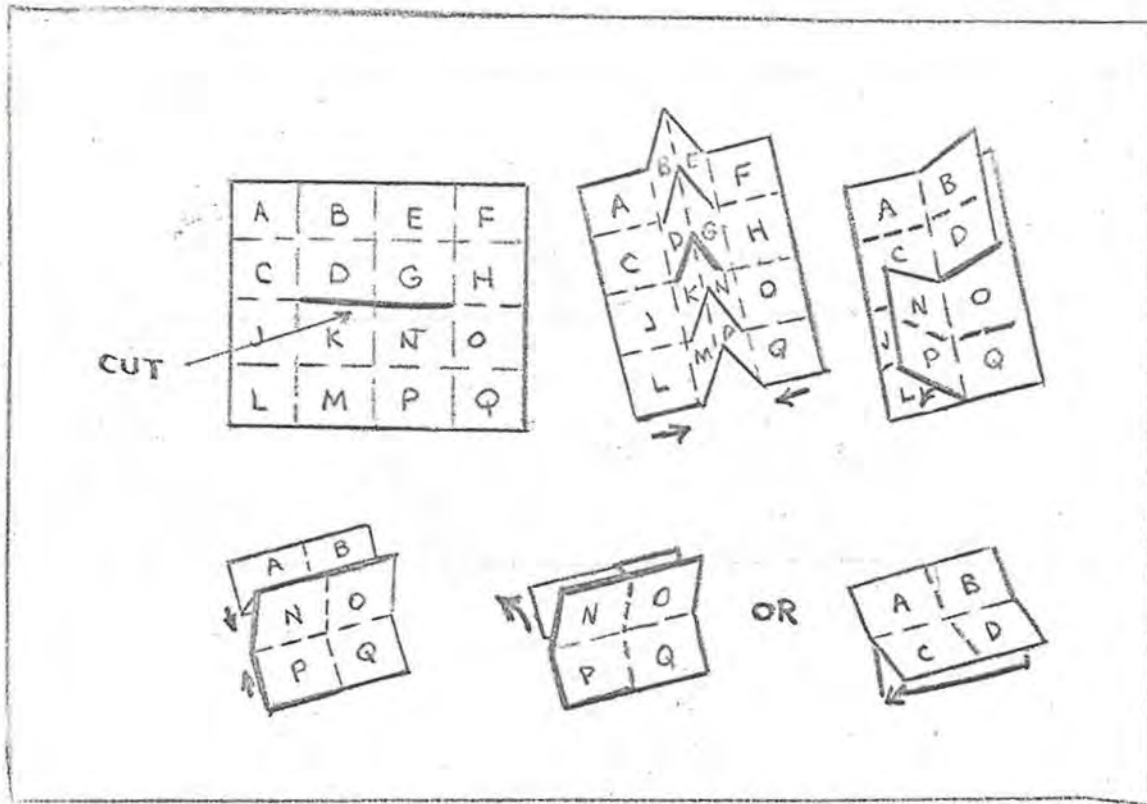

FIGURE 56. HOW TO SLIT AND FOLD A MAP

135

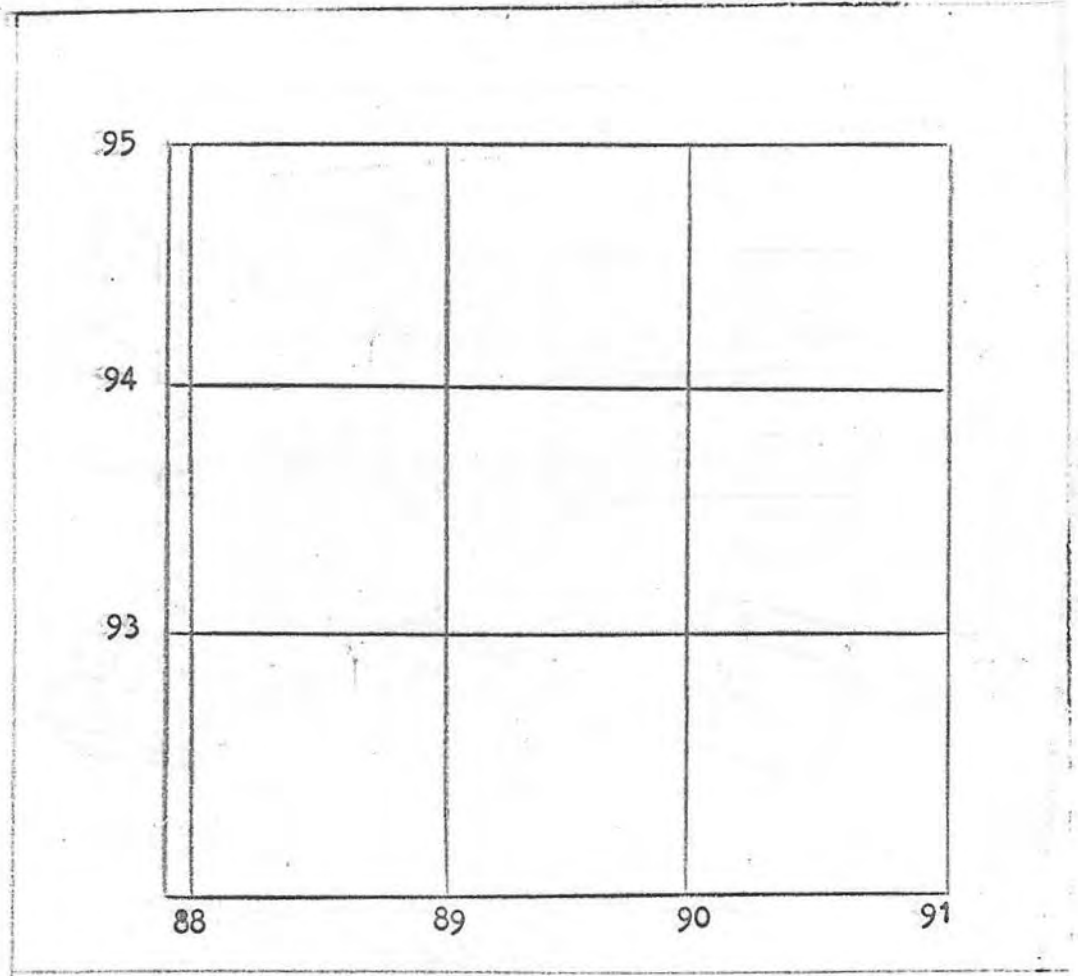

FIGURE 57. GRID LINES

136

STATIC DEFENSE EXERCISES

1. STATIC DEFENSE

During the Tactics Phase of this course, the student will participate in several hours of Static Defense Exercises that will employ many facets of the training that you will have received to that date. These Static Defense Exercises will be planned to simulate as closely as possible the defense problems that the student will face when assigned to a unit in a combat zone. Regardless of the mission assigned to your unit, static defense planning and immediate action drills will constitute an important part of your mission. No Army or unit is totally offensive or totally secure in its bivouac while operating in an insurgent environment.

Defense of the base camp will be a continuing problem. Your static defense exercises while in training will be planned and conducted to include TSSE employment, Weapons Employment, Internal Security measures, work priorities and the construction of Field Fortifications.

2. FIELD FORTIFICATIONS

Most of the fortifications that you will learn to construct in the field will be based on the two basic foxhole positions illustrated in Figures 58 and 59. While training in the field and in academic classes, your cadre will teach you the variations of these basic foxholes, such as cover, concealment, two and three man positions, sandbagging and permanent construction. Since combat operations will include these important construction techniques, the student should apply his imagination and attention to the material presented.

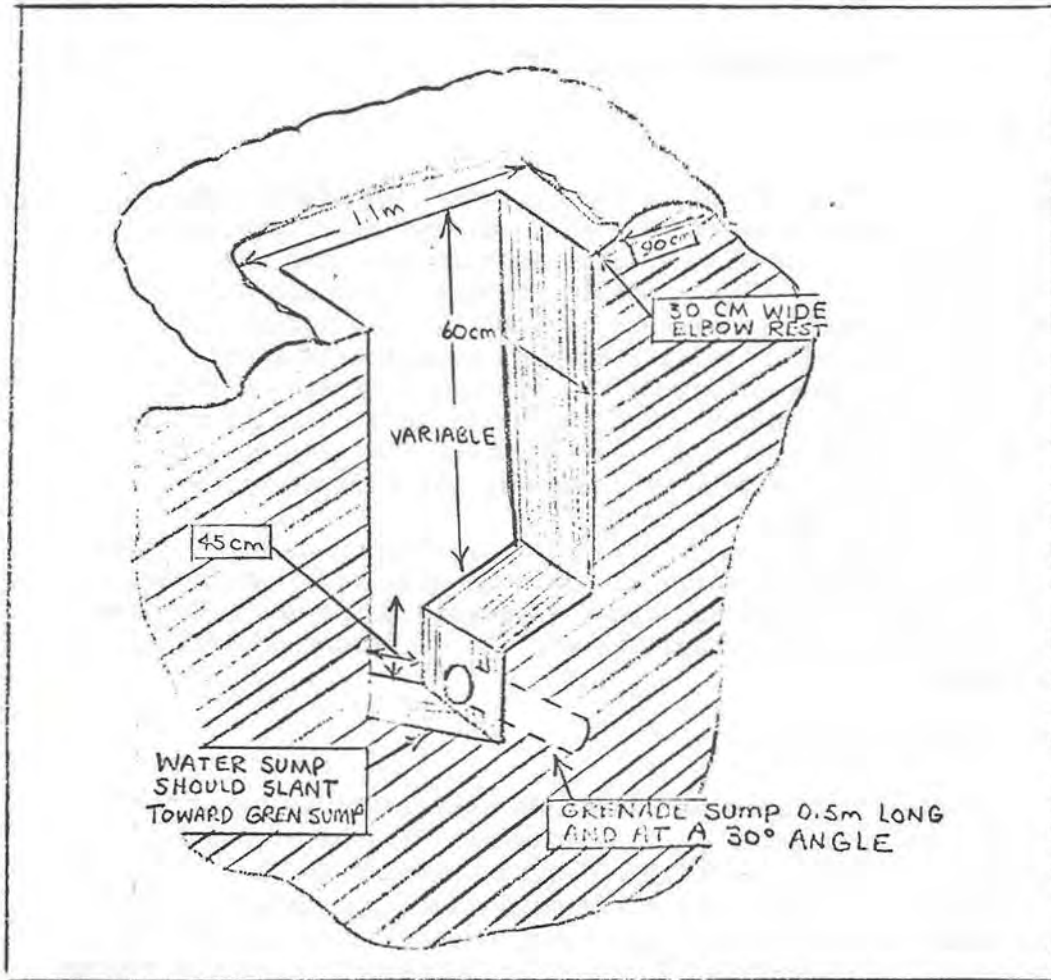
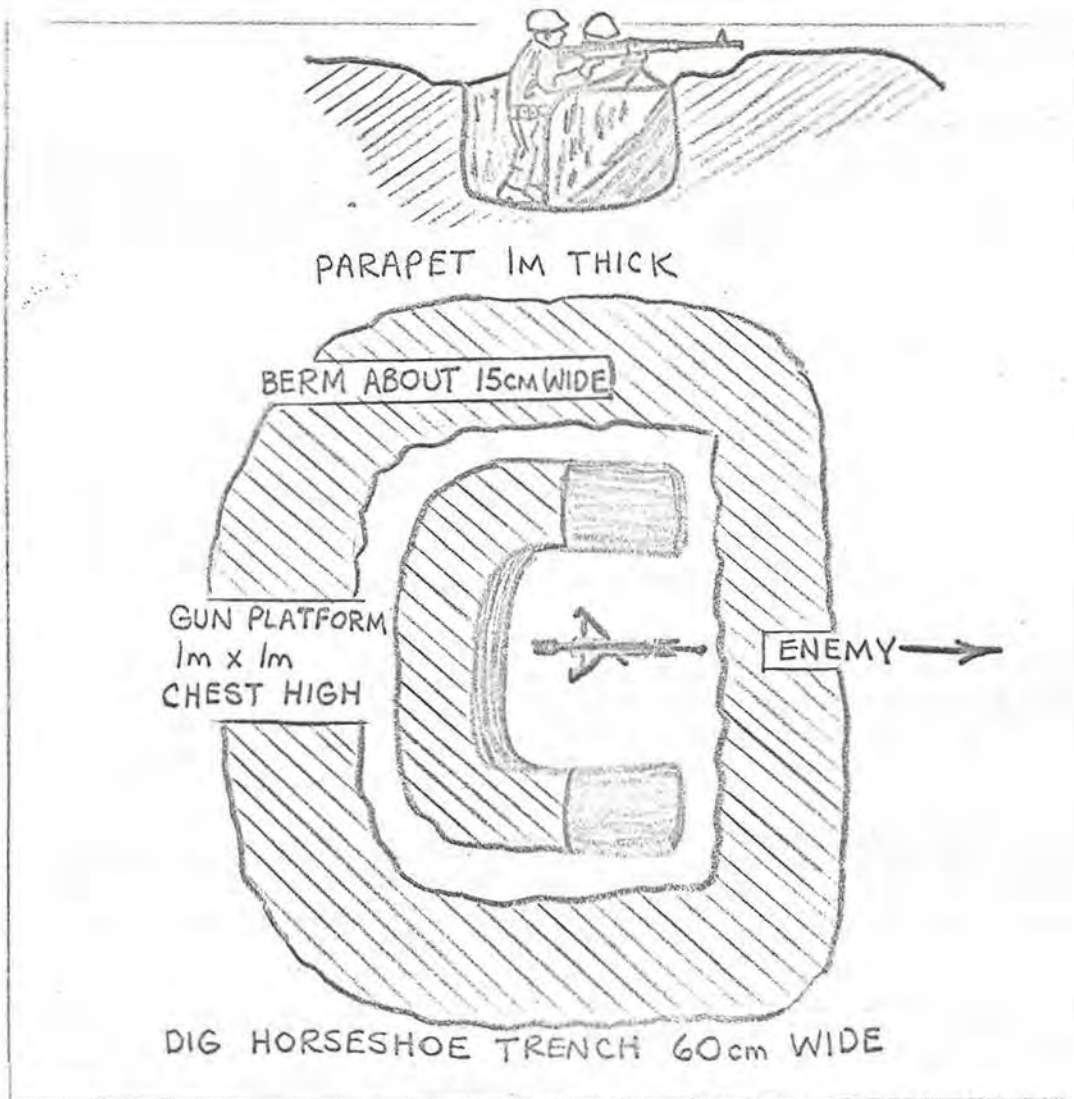

FIGURE 58. ONE MAN FOXHOLE FOR RIFLEMAN

138



139

FIGURE 59. CREW SERVED WEAPONS EMPLACEMENT

BOOBY TRAPS

1. INTRODUCTION

Booby Traps are favored devices of the guerilla. They are usually inexpensive, relatively easy to install, and with minimum effort have maximum effect. Grenades, spike traps, poison arrows and a variety of other means are employed to harass, slow down, confuse and kill friendly forces. The forms of these weapons are limited only by the imagination of the designer.

2. COMMON BOOBY TRAPS

Grenades are commonly used as booby traps because they are light in weight, easy to carry and conceal, and readily adaptable. They are frequently put in trees or on fences and also along trails that friendly forces are expected to use, with trip wires strung across the pathway. Munitions, particularly artillery and mortar shells, have also been rigged for detonation as booby traps.

a. Cartridge Trap: This common booby trap is designed to maim the foot of the individual that steps on this trap. It consists of a cartridge planted in the ground with the projectile protruding very slightly, and under pressure from the foot, will fire upward when the primer strikes a nail or other firing device. (Figure 60).

b. Grenade On Trail: The most common type of booby trap consists of a trip wire stretched across a trail, anchored to a small bush or tree and to a friction type fuze in the grenade. Most other booby traps are a variation of this idea. (Figure 61).

c. Grenade At Gate: In most cases the grenades are buried (shallow) under the gate. A short trip wire is attached to the gate so that when it is moved even slightly, the grenade is detonated. (Figure 62).

d. Bamboo Arch: Recently the Viet Cong guerillas in Vietnam have been making bamboo arches across trails. A grenade is secured at the top of the arch and the trip wire secured to the grenade. Any contact with the trip wire will detonate the grenade. This is employed most effectively at night as a warning device. The location of the grenade achieves a large casualty radius. During the day the trip wire is loosened from the ground and wound around the bamboo arch to allow use of the trail to the guerillas. (Figure 63).

e. Grenade Daisy Chain: The daisy chain of grenades is made by first attaching a grenade to a tree or bush and tying it in such a manner that the handle is free to activate if the safety pin (which is attached to a trip wire) is pulled. Successive grenade handles are held under tension by a line from the preceding grenade. All grenades but the first one have their safety pins pulled. When the trip wire to the first grenade is tripped, the safety pin is pulled and the safety handle flies off, allowing the grenade to detonate. As the grenade detonates, it releases the string to the next grenade allowing the handle to fly free, detonate and, in turn, release subsequent grenades in the line. Placed along a trail, this arrangement is very effective against closely spaced members of a patrol (Figure 64).

f. Command Detonated Grenades: In this situation the guerillas have tied a series of hand grenades to bushes, trees, or in grass clumps along trails or avenues of approach to their positions. The safety pins of the grenades are linked by fish cord or wire to an enemy position overlooking the site. When our patrols enter the killing zone of the grenade ambush site the one or two man team, by pulling the string or wire, can detonate one or any number of grenades without warning. (Figure 65),

3. MAN TRAPS

Spiked foot and man traps are common types of booby traps found in insurgent areas. The spikes may be sharpened bamboo sticks, or they may be barbed wood or metal spikes emplaced in wooden, concrete or metal blocks. The spiked devices are placed in holes along routes of movement and carefully camouflaged to prevent detection or they can be placed on top of the ground. Three of the more common man traps include:

- a. Punji "Bear" Trap: A man stepping into the punji pit hits two boards or steel plates with steel spikes affixed, the boards or plates then pivot, wounding the leg above the area protected by the hoet. (Figure 66).
- b. Man Trap: Prone shelter constructed with concealed punji stakes. (Figure 67).
- c. Bridge Spike Trap: Used on small plank type bridges crossing ravines, irrigation canals, etc. Plank is cut at the middle, covered with mud, and punji stakes are placed under the plank, causing the individual falling through the plank to receive severe foot and leg injuries. (Figure 68).

4. BOOBY TRAP TRAINING

This section is not meant to be all inclusive. During your training you will receive extensive training on the latest booby traps, many of them no doubt developed since this handbook was published. The guerilla has an international reputation for daring and imagination, and if you apply your imagination to the counter booby trap training you receive, the chances of your being injured by these devices will be reduced.

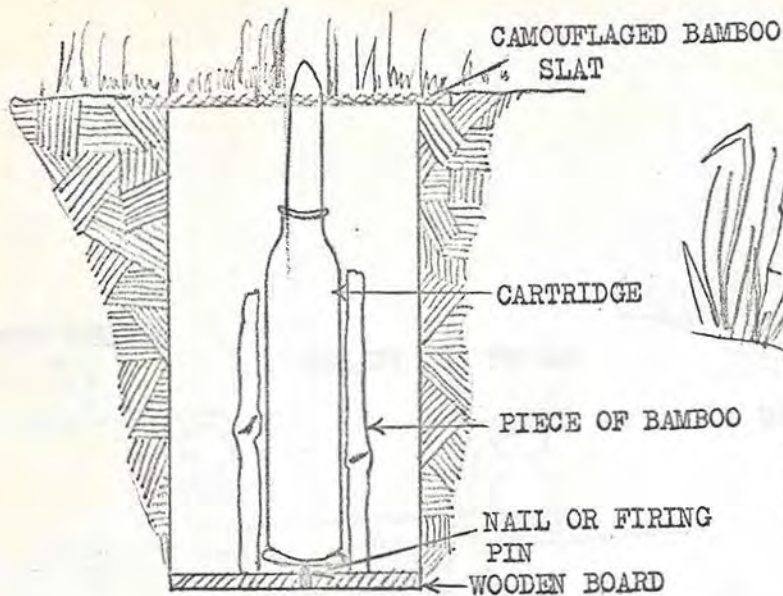

FIG 60. CARTRIDGE TRAP

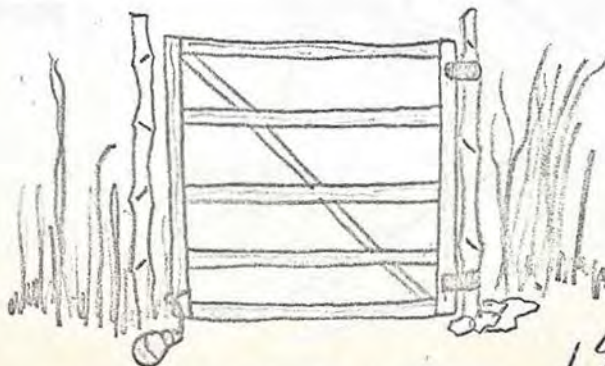
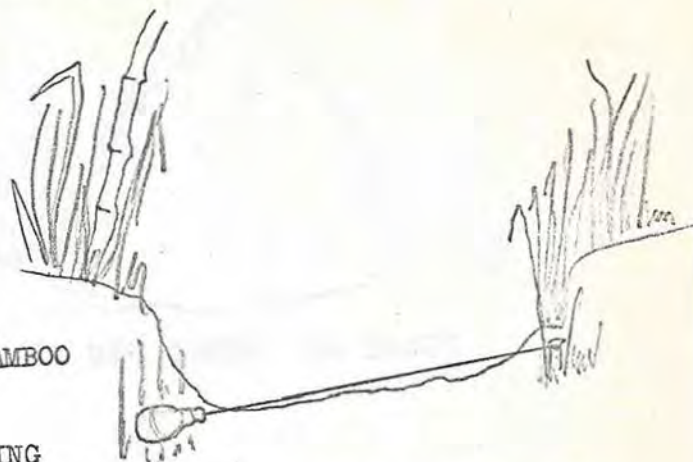

FIGURE 62. GRENADE AT GATE

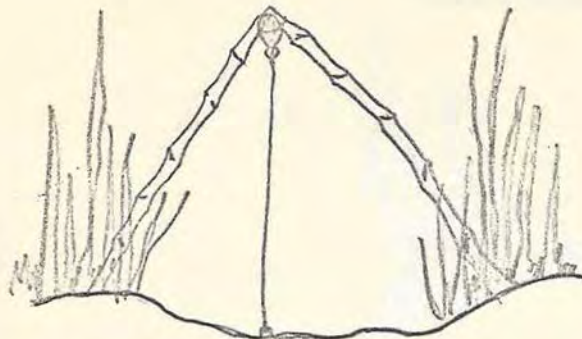

FIGURE 63. BAMBOO ARCH

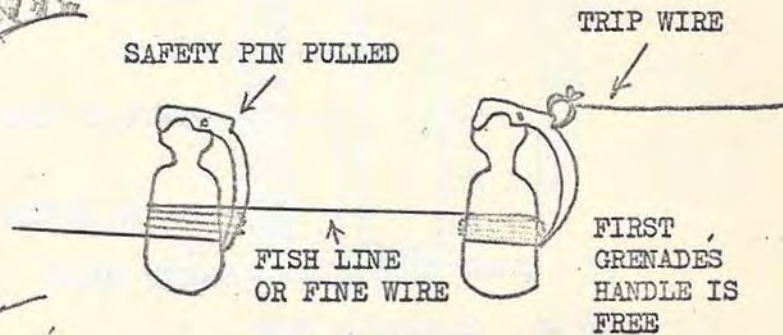

FIGURE 64. GRENADE DAISY CHAIN

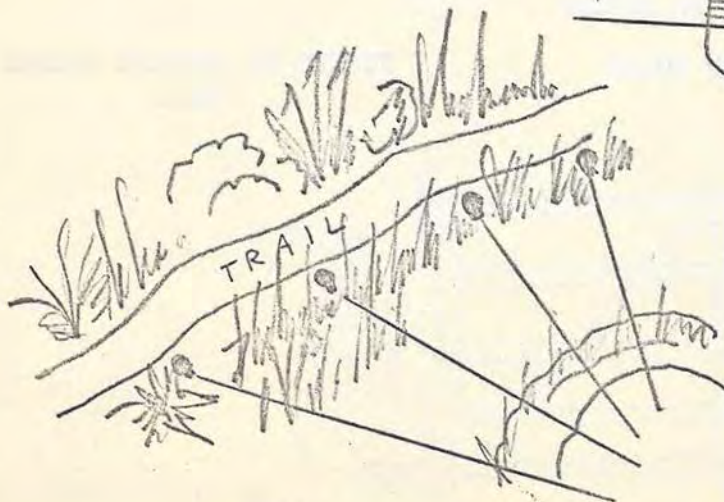

FIGURE 65. COMMAND DETONATED GRENADES

144

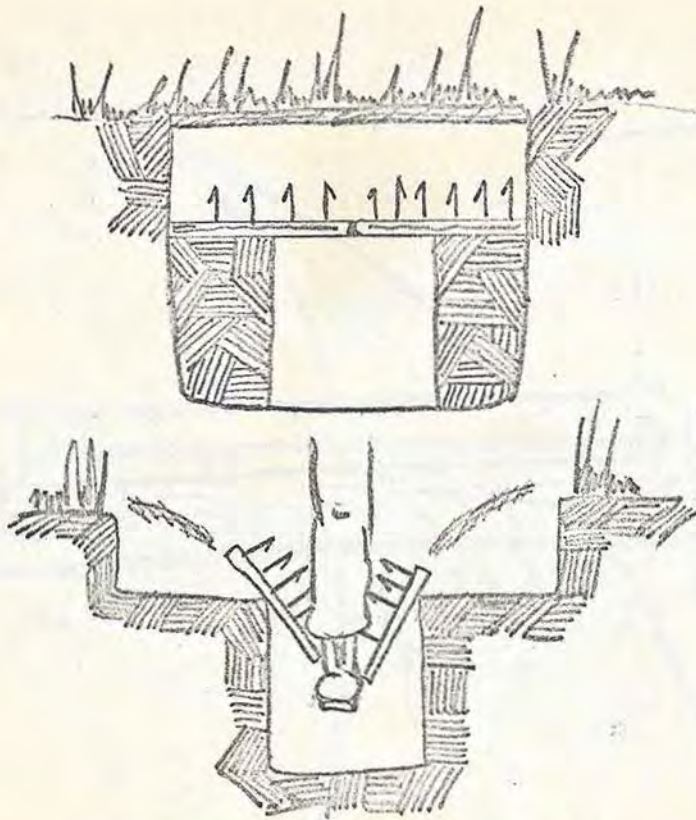

FIGURE 66. PUNJI "BEAR" TRAP

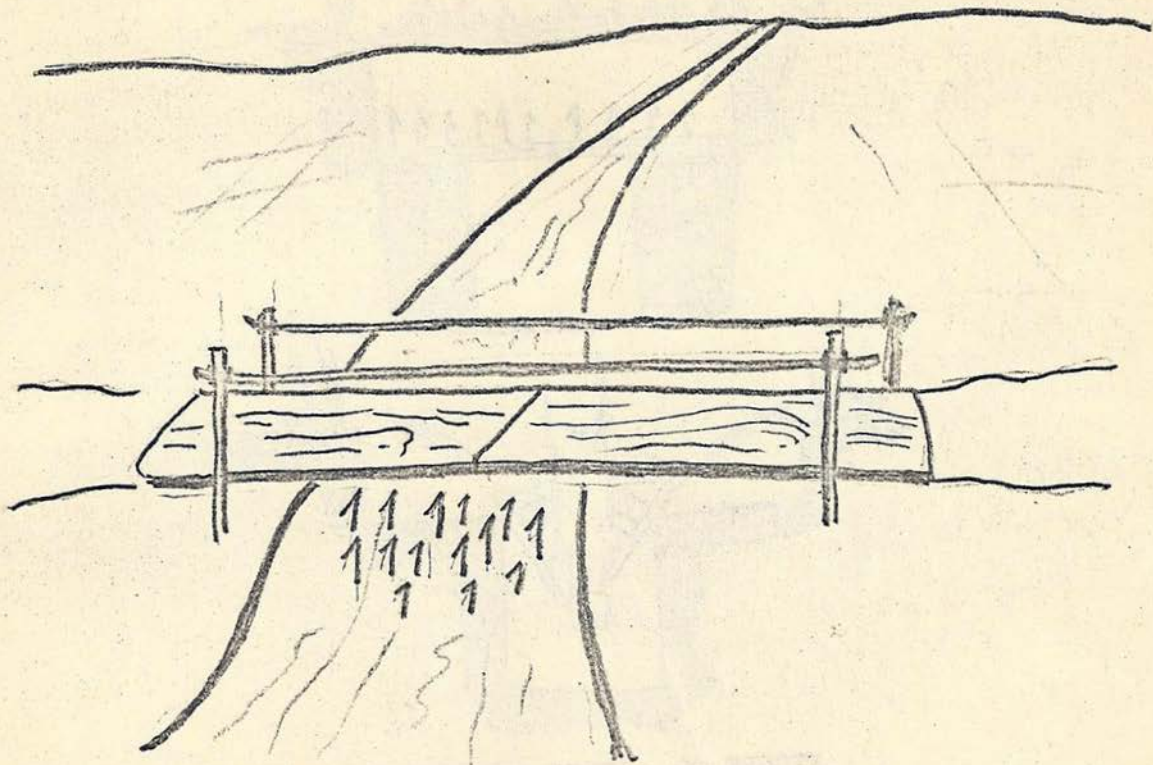

FIGURE 68. BRIDGE SPIKE TRAP

